

Freedom Commercial Wheelchair Lifts

Installing the Commercial Trus-T-Lift 750 system is simple, smooth and easy.

Our commercial wheelchair lifts have been manufactured for over 20 years and have national and international experience ensuring our commercial Trus-T-Lift systems to meet your local code requirements.

The codes can be confusing with over 9 different national codes. Each state (and some municipalities) follows 1 of the 9 national codes and will often make changes and/or additions to it. In addition, individual elevator inspectors may have their own requirements for a particular installation. In most of the country the lift must be installed by a licensed elevator installer, however in some areas a license is not required.

We can help you have a successful project. Gather information on the project such as building address, lifting height and lift configuration, local building /elevator department code requirements, and get a copy of the building plans. Send us this information and we can provide you with a quotation and installation drawings for the building inspector.

Our Freedom Trust-T-Lift is available with lifting heights of up to 28" or 52". Choose straight through or adjacent access to suit your project application.



Commercial Wheelchair Lifts Standard Features

- Smooth and quiet performance
- 750 lbs (340 kg) Lift Capacity
- 28" and 52" lifting height (adjustable to specified height)
- 8 feet/minute lift speed
- Constant pressure Soft Touch control pads for ease of operation, large 2"x8" flippers for both directions
- Solid platform and under platform safety plates
- Emergency alarm and light package
- Solid handrail
- Carriage gate
- Upper landing gate
- Electrical/Mechanical interlocks
- Keyed remote call stations, upper and lower
- Non-skid surface
- 18" extra wide positive action reversible toe plate for universal access
- Quick and easy set up and adjustment
- Synchronous Geared Belt with Acme screw-nut drive for maintenance free, quiet operation (much lower maintenance than belted hydraulic systems)
- Extreme weather resistant design
- Zero load start for cold weather climates (drive system allows motor to get up to full speed before lifting).
- All mechanics are fully enclosed, yet easy to access through the rear or front of the housing unit.
- Attractively finished in a durable off-white baked on finish.
- Non load bearing backup safety nut on lift shaft
- Fuse box accessible from carriage
- Keyed emergency stop
- ASME 18.1 compliant
- UL and CSA certified

Options

- 12V DC battery backup

The lift when configured with appropriate options can meet the ANSI A1 7.1 Part XX, Section 2100 codes, as it relates to commercial applications.

Installation and Maintenance

We recommend a 6'x 6' concrete pad with a minimum 4" thickness.

Maintenance of the vertical platform lift unit shall consist of regular cleaning of the unit, protection of the painted surface of the unit.

Warranty

All parts are warranted against manufacture's defect for a one year period from the date of purchase. Parts are FOB Factory and shall not include labour costs required to replace the defective part(s).

52" Commercial Lift with a right tower Straight Through Access

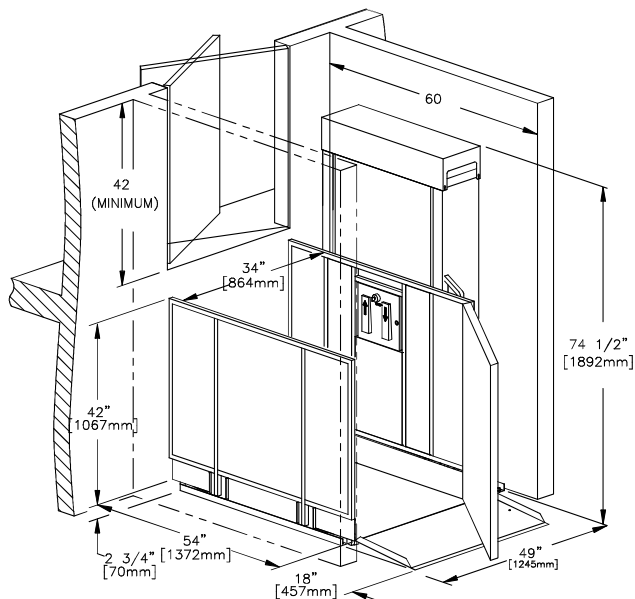

52" Commercial Lift with a right tower Adjacent Access

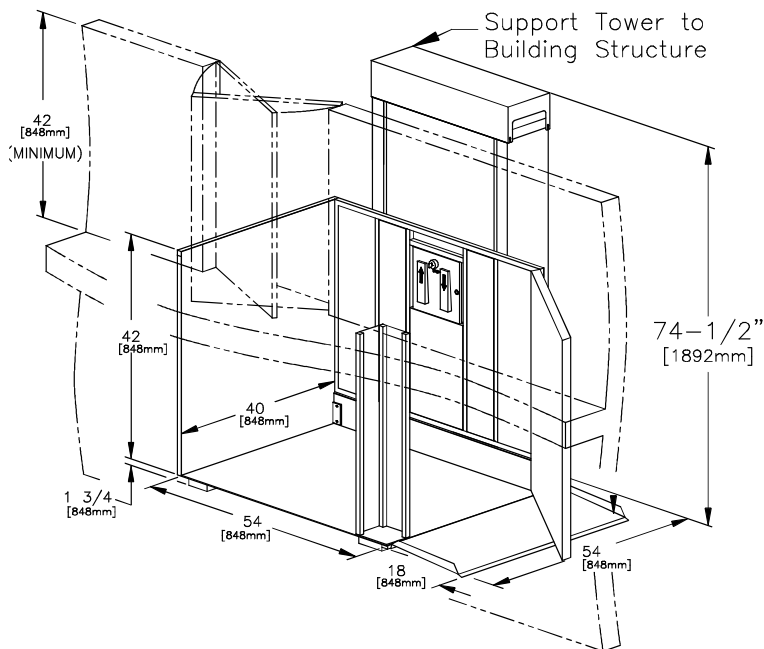

Note: 52" lifts with right tower shown, left tower available. Also available are 28" lifts, towers left or right



Carriage Gate

Trus<T>Lift is a trademark of RAM Manufacturing,

U.L. and C.S.A. Certified