

Trus<T>Lift™ 750 Installation and Operation Manual

Copyright 2013



Revision D – Oct 29, 2014

Phone 1-877-947-7769
www.FreedomLiftSystems.com

Contents

| | |
|--|----|
| Section 1: Intro..... | 2 |
| Section 2: Safety | 2 |
| Section 3: Operating Instructions | 3 |
| Section 4: Installation – Site Preparation | 5 |
| Section 5: Installation –Basic Lift Assembly..... | 6 |
| Section 6: Installing Options | 12 |
| Section 7: Mounting the Tower to a Wall..... | 29 |
| Section 8: Tall Tower Lifting Instructions | 33 |
| Section 9: Maintenance | 36 |
| Section 10: Basic Trouble Shooting | 44 |
| Appendix A: Trus <T> LIFT Assembly Drawings (with part numbers)..... | 46 |
| Upper Landing Gate Drawing (with part numbers) | 48 |
| Appendix B: Basic Electrical Drawing..... | 49 |
| Appendix C: Required Tool List..... | 51 |
| Appendix D: Maintenance Log..... | 52 |

Section 1: Intro

Thank you for selecting the Trus <T> Lift. When operated properly the Trus<T>Lift is designed to provide years of trouble free service. This manual is provided to show you how to operate the lift safely and efficiently. Please read this manual thoroughly before installing and operating your lift for the first time. We recommend your lift be installed and serviced by a qualified service technician.

Section 2: Safety



Read all instructions thoroughly before installation or use of this lift. Failure to do so could result in serious injury or death.

Refer to local building codes, elevator codes and elevator authorities to ensure installation is safe and meets your local regulations.

The tower component of all lifts over 52" travel must be secured to the building for additional support. For commercial installations we recommend the tower be secured to the building for all lifting heights.

We recommend your lift be installed and serviced by a qualified service technician.

Do not override any of the safety devices provided with the lift

Make sure that there is nothing obstructing the carriage travel before operating the lift.

Make sure there is a minimum of 2in (50mm) and a maximum of 3in (75mm) clearance between any part or edge of the carriage that could possibly be used as a supporting handhold and any part of the fixed installation to prevent the trapping of a hand during the travel of the carriage.

The lift is intended for use by one passenger and one wheelchair only, to a maximum of 750 lb. (DO NOT OVERLOAD THE LIFT).

Make sure that the passenger and the wheelchair are completely on the carriage before raising or lowering the lift.

Please use the handrails while the carriage is in motion.

This list may not be exhaustive, due care around mechanical equipment should be observed. If uncertain, please contact the manufacture or a qualified installer.

Section 3: Operating Instructions

Plug the unit into your power supply. On the end of the power cord you will find the gold key to open the control box, use this to open the main control box by pushing in hard on the box with one hand to compress the weather seal while turning the key with the other hand. All other keys for the unit will be hanging on the back of the control box door.

To raise or lower the carriage press either the UP or DOWN paddle (See Figure 1) and maintain continuous pressure on the paddle until the lift stops automatically at the landing. If you decide to change the direction of travel of the lift before it reaches the landing, you must release the paddle and wait for the lift to come to a COMPLETE STOP before pressing the other paddle.

Your lift features the patented zero load start system that ensures the best performance in extreme hot or cold by reducing the stress on the drive system. When you reach the bottom landing the motor will continue to run for a couple of seconds and when you start up from the bottom landing the motor will run for a couple of second before the platform starts to move.

If you need to stop the lift before it reaches the landing, simply release the UP or DOWN paddle and the carriage will stop immediately. You can also stop the lift by pressing the red STOP button (See Figure 1). To release, simply pull out the button.

A key switch is located near the UP and DOWN paddles to prevent unauthorized use of the Trus<T>Lift. The key is removable in both positions. The switch may be turned off and the key removed making the paddles on the carriage inoperable. When you wish to use the lift again insert the key, turn the switch on, and remove the key. It is recommended that you have the key readily available whenever operating the lift.

Figure 1: Location of UP, DOWN, and STOP controls.

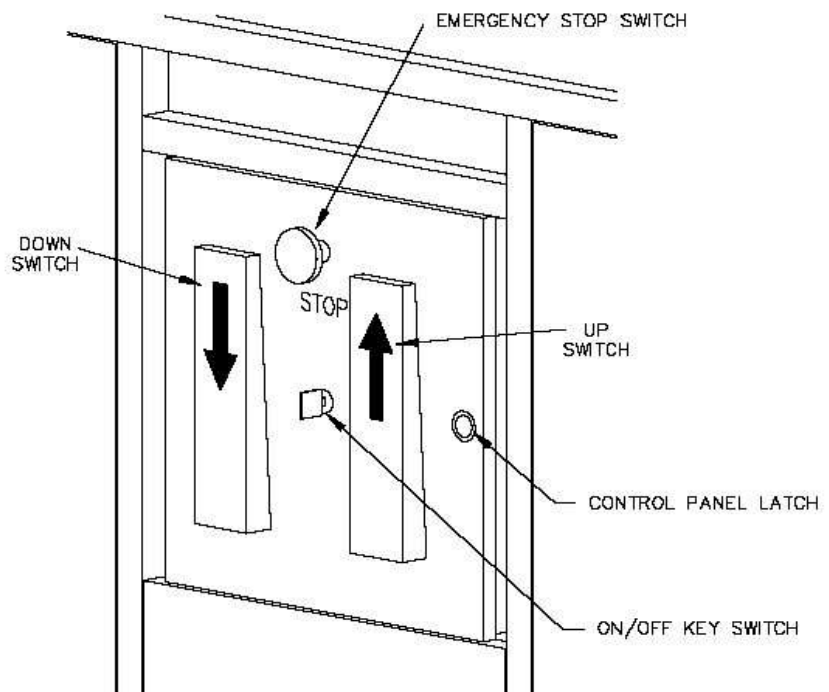

MANUAL CRANK OPERATION

If a power outage occurs while the lift is in use and a passenger is stranded between landings, the carriage can be manually raised or lowered using the Hand Crank Tool provided. First verify manual cranking is required, ensure the stop button is pulled out, the control key is turned on and the lift is plugged in. If manual cranking is still required follow these steps:



When manual cranking the lift there is a pinching risk between the belt and the pulleys. Keep your hands, hair, clothing and jewellery clear of the drive belt.

Unplug the power cord

Remove the top cover of the lift

Use the 15/16" socket and ratchet provided to crank the bolt on the top center of the tower (See Figure 2).

Turn the Hand Crank Tool clockwise to raise the lift and counter-clockwise to lower the lift.

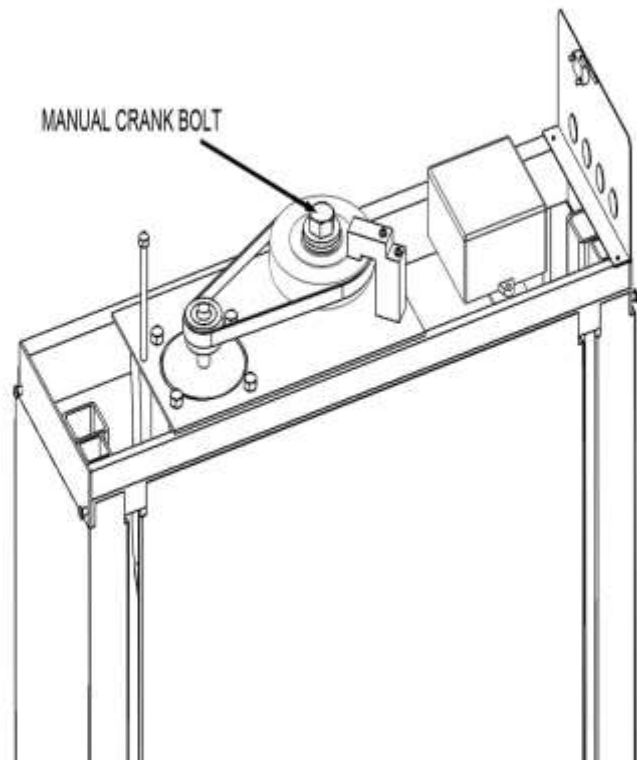
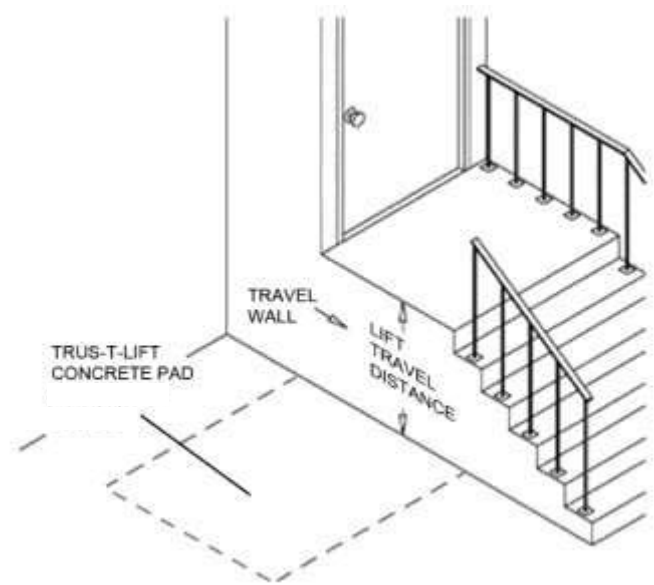

Figure 2: Manual Crank Access

Section 4: Installation – Site Preparation

4.1 Mounting location

The Trus<T>Lift requires a solid, smooth, and level mounting surface. When mounting on a concrete pad ensure there is a minimum of 6in from any anchor point to the pad edge to prevent cracking the concrete. Plan for a minimum of 60in x 60in additional space (not including the toe plate) on the lower entrance side to allow enough space for the wheelchair to manoeuvre onto the lift. The specific size of the lower landing may vary depending on the specific lift in question and you should consult your RAM dealer or RAM directly to ensure you prepare the site correctly.



The mounting surface must be solid enough to support the lift and its maximum rated load. If you need a load diagram please contact your RAM dealer or call 1-800-563-4382.

Note: The Trus<T>Lift ships with four 3/8" x 2 3/4" concrete wedge anchors.

Figure 3: Typical Installation

For wedge anchor installation information visit

<http://trustram.com/concrete-anchor/>

4.2 Travel Wall

The travel wall is the wall below the upper entrance/exit point of the lift (Figure 4). This wall should be vertical, smooth, and free of gaps or protrusions for the entire travel distance of the lift.

4.3 Power

A 110 VAC 15A electrical receptacle must be provided within 6 feet of the tower side of the lift. You can use an extension cord if required. Total length of line including the cord attached to the unit must not exceed 20 ft. Use only 14 gage extension cord. Residential lifts should use a dedicated circuit where possible. Commercial applications require a disconnect and a dedicated circuit.

Section 5: Installation –Basic Lift Assembly

RAM manufactures numerous lift configurations. For lifts that have additional options (including commercial lifts) please see Section 6. The basic lift assembly instructions apply to all lifts regardless of configuration.

Position the tower on the mounting deck close to the final install position. (Note: choose a location where the carriage components can be assembled easily with the intention of moving the unit into final position after tower, base legs and carriage are fully assembled). (Figure 4)

Slide the base legs under the base angles on the tower.



WARNING Use safe lifting practices along with a dolly or other appropriate lifting equipment to move the tower into place.

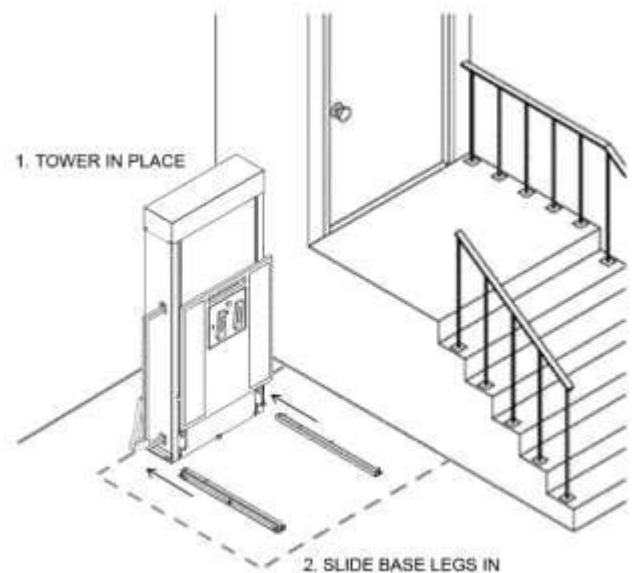

Figure 4: Position Tower and Base Legs

Securely fasten base legs to the tower as shown in Figure 5 using provided $\frac{1}{2}$ NF x $1\frac{1}{4}$ " cap screws, $\frac{1}{2}$ lock washers and $\frac{1}{2}$ flat washers.

Adjust the front and back base leg load-support screws to lift the base frame slightly off the ground.

Note: Do not attach the base frame to the ground at this point, this setting will ensure the lift is supported on the outer points of the base frame for maximum stability. Later in the process the mid-load support screws will be adjusted to just touch the floor with no load on the carriage before the base legs are anchored to the ground.

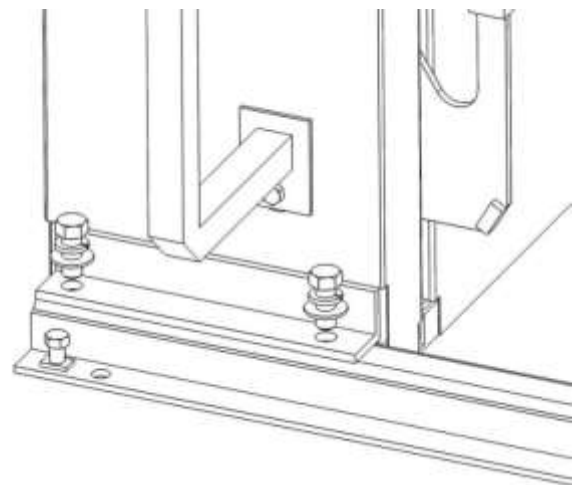

Figure 5: Attach Base Legs to Tower

5.1 Attach the platform to the tower

Note: If the lift was purchased with any upper or lower interlocks, the lift will not run with the control paddles until the interlocks are properly wired into the control box at the top of the lift. See section 6 for options

Raise the guide frame using the manual crank or by temporarily plugging the unit in to a power outlet. Slide the platform into place on the base frame (Figure 6), be careful not to scratch the base frame.

Hint!! Use packaging foam from the shipping crate to protect the base legs when installing platform.

Lower the guide frame to line up bolt holes on the carriage and install the bolts (Figure 7). Note: tighten the bolts until the end of the bolt is 1/8" of an inch out of the lock nut, do not over tighten the bolts.

Hint!! You can get a better view of the bolt extending through the nut by removing the plastic panels beside on the control box on carriage wall.

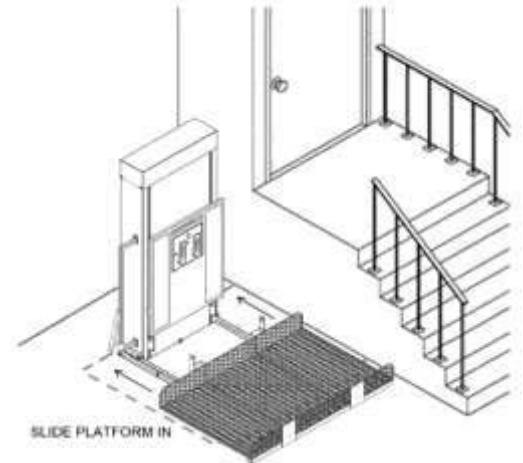
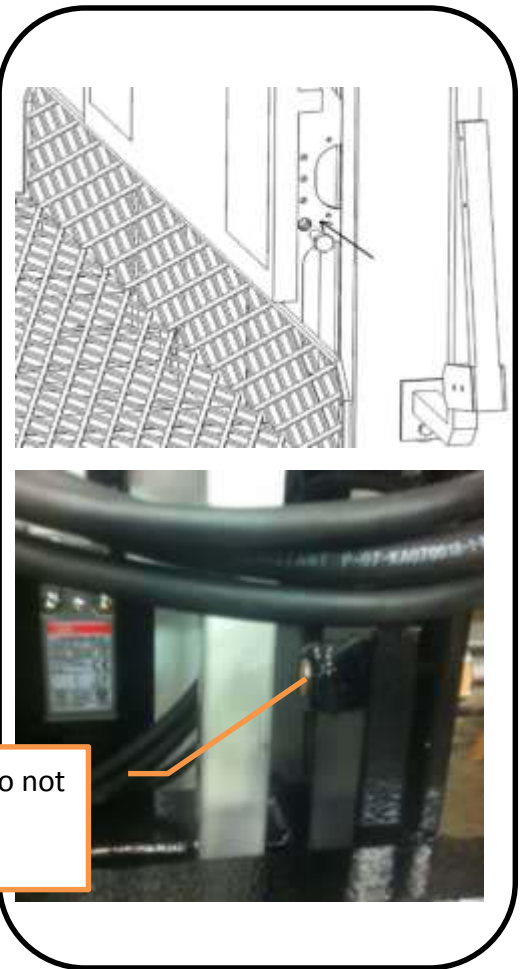

Figure 6: Slide Platform In



1/8in clear of end of nut – do not over tighten

Figure 7: Attach Platform

5.2 Install handrail

Install the handrail using 5/16" NC x ¾ Cap screws with 2 washers and a nut on each cap screw as shown in (Figure 8).

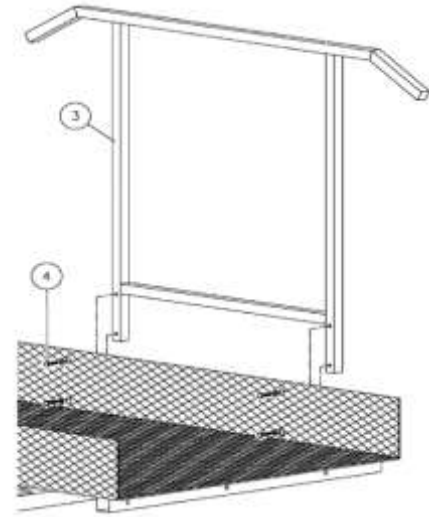

Figure 8: Install Handrail

5.3 Install Toe plate assembly

Raise the carriage to a comfortable working height, install the toe plate and tighten all the bolts (Figure 9)

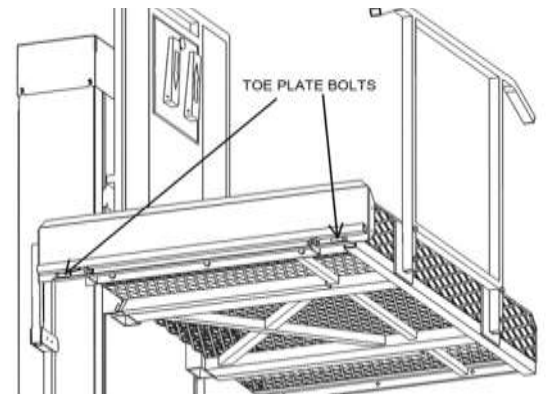

Figure 9: Install Toe Plate

Install the toe plate rocker arm as per (Figure 10)



WARNING The toe plate is designed to resist a static force of 125 Lbs. to prevent a manual wheel chair from rolling off of the platform. It is recommended that a carriage gate is used to provide additional protection when lift is being used by powered wheelchairs, powered scooters, standing persons or if the user has limited control of their wheelchair when entering the lift at the upper landing.

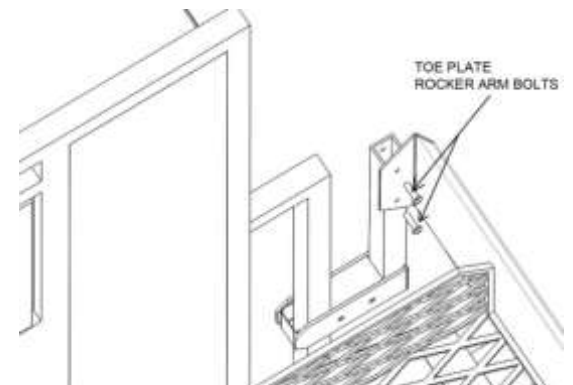

Figure 10: Attach Toe Plate Rocker Arm

5.4 Level the deck and adjust clearance to travel wall

Using the two platform levelling screws provided (Figure 11) Adjust the platform tilt so that the platform is level with both top and lower landing when a load is applied to the carriage. In most cases setting the levelling bolts to have the platform be even at 50% of expected working load is preferred.

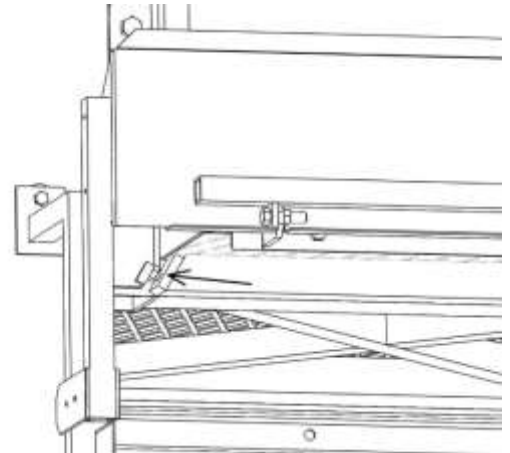

Figure 11: Platform Levelling Screws

Position the tower and adjust the front and back base leg levelling screws (shown in figure 11a) so that the carriage runs evenly along the travel wall with a gap between the platform edge and travel wall of less than 5/8" (15 mm) for installations in Canada and 3/4" for installations in the USA. An example of good running clearance and poor running clearance is shown in figure 11b.

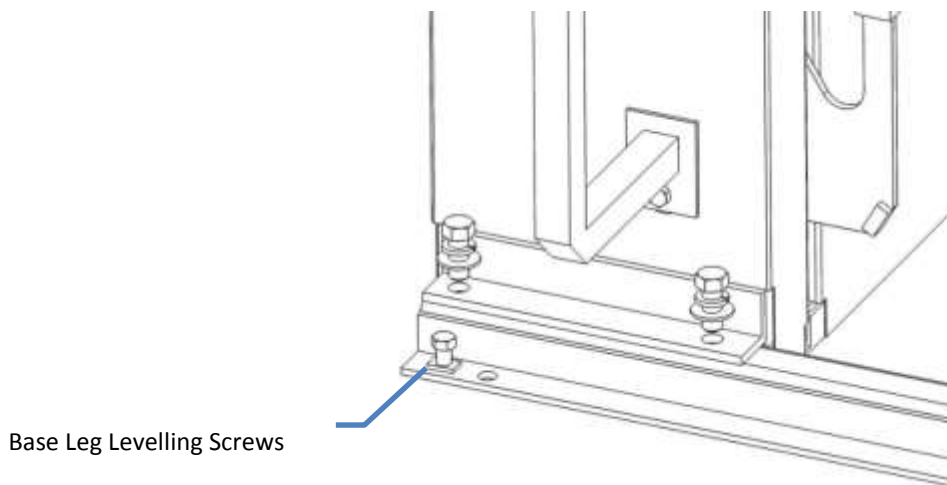

Figure 11a: Base Leg Levelling Bolt Location

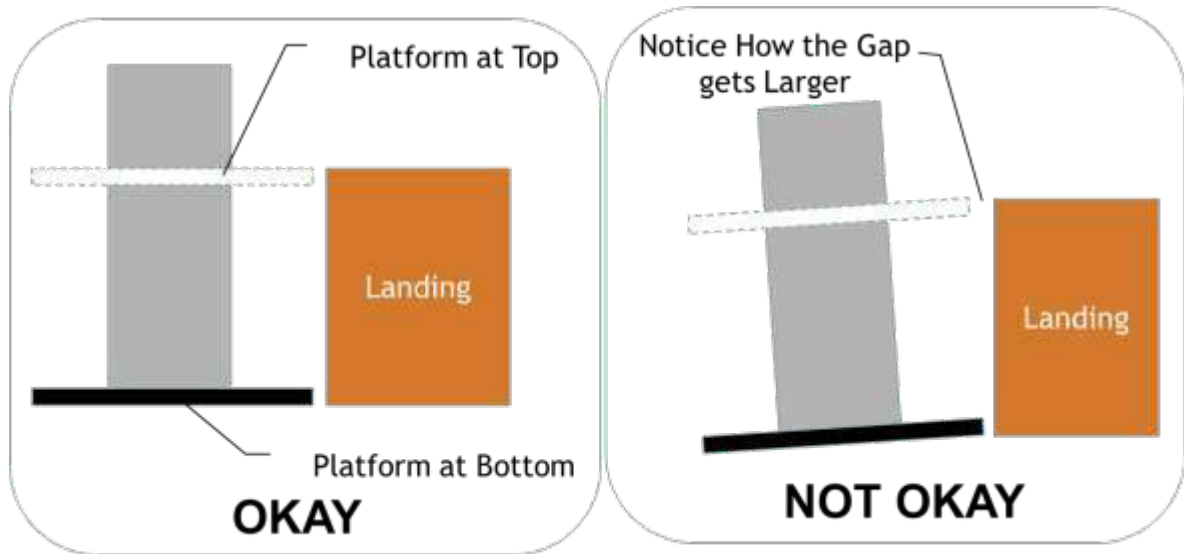

Figure 11b: Example of Poor and Good Travel wall alignment

5.5 Secure the lift to the building

Drill 3/8" holes through mounting holes in base legs. Use provided concrete anchors to attach base legs to concrete. (If attaching to another material then concrete use appropriate fasteners for the material you are working with).

If working with a commercial insulation or if lifting height is greater than 52", attach the top of the tower to the building prior to attaching the base frame.

See Section 7– Mounting the Tower to a Wall.

Lightly tighten middle levelling bolts until they touch the concrete pad, and then tighten them an additional ½ turn.

5.6 Setting the Upper and Lower stopping Positions (Upper and Lower Limits)

The upper stopping point (upper limit) bracket is located on the front cover support tube behind the front cover of the main tower (Figure 12). Remove the top cover and front cover, and use a Robertson screwdriver to loosen the upper limit bracket. Slide the bracket down until the upper limit switch clicks. Tighten 2 screws on the limit to hold it in place. Move the lift down and back up to test that the limit is set at the correct height to stop the platform at the upper landing. Once the limit is in the correct place, use the self-drilling and tapping screw provided to set the limit in place.

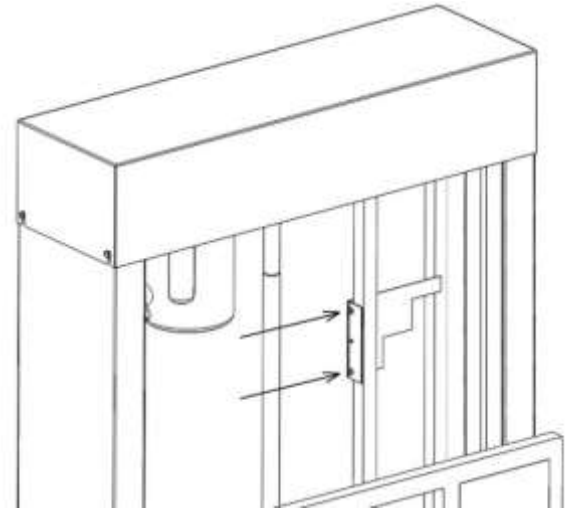

Figure 12: Set the Upper Limit Bracket

When replacing the front cover ensure that the gap between the side covers and the front cover is even. If it is not even damage could be done to the electrical/control cables that run between the panels as they move up and down with the carriage.

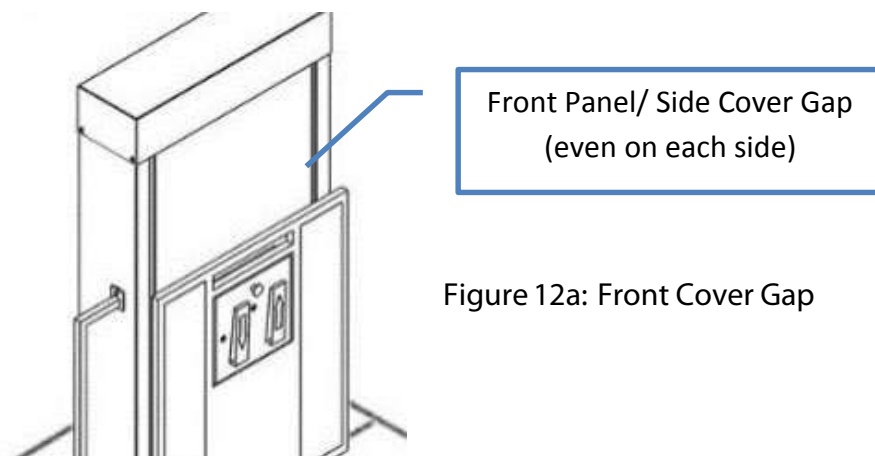
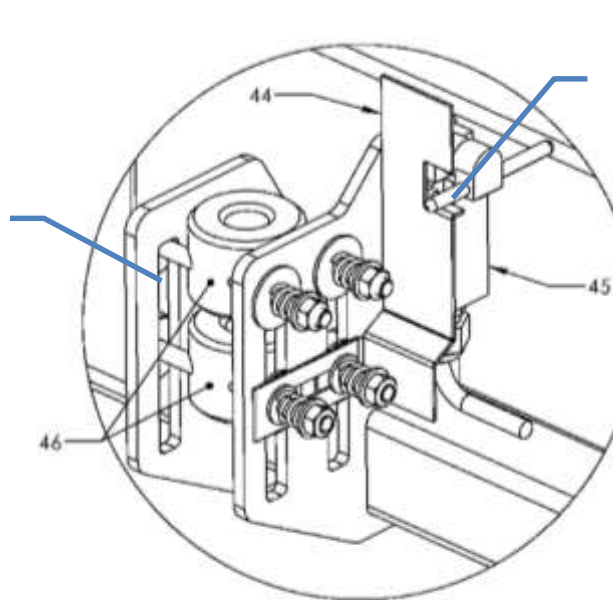

Figure 12a: Front Cover Gap

The lower stopping point (lower limit) for a RAM Trus-T-Lift™ is not typically set in the field. With RAM's Zero-Load Start system the lift turns off automatically when the carriage platform reaches the ground. The lift will come to a stop as the lower limit sensor is actuated. This occurs as the drive nuts continue to move through the slots in the guide frame for a short time after the platform comes to a rest on the lower land

As platform or mechanical stops (for lifts equipped with a safety pan) comes in to contact with the ground the bolts will travel down in the slot bringing the safety bracket (item 44) down as well.



Lower limit switch (item 45) not activated yet but as drive nuts (items 46) travel further the switch will get pressed and stop lift movement

DRIVE NUT/LOWER LIMIT SWITCH DETAIL

In cases where the RAM Trus-T-Lift™ is being used to replace a product that had a pit that was deeper than that required for our product you may need to stop the lift before the lift platform comes in to contact with the bottom of the pit. In these cases you can use some form of rigid blocking that will withstand the full load of the landed carriage platform. If you are uncertain whether this is the case please consult your RAM Dealer or contact RAM technical support.

Section 6: Installing Options

The installation of a lift with options differs from a basic unit in that it requires all peripheral safety devices (i.e. upper interlock, lower interlock and safety Pan) to be wired up at least temporarily in order to run the motor.

6.1 Identify the Optional Components for your Lift

Not all lifts are shipped with the same components. Be sure to identify all the options you have purchased before assembly. Follow each step carefully to ensure proper functionality. Parts List - The options for the Trus<T>Lift are pre-assembled and tested in the factory before shipping. The lift is then disassembled into its separate components. All fasteners required to assemble the lift are re-installed in their respective positions after disassembly, except for the Lower Mechanical Stops (5/8" X 3" Carriage Bolts) included with the small parts bag.

6.2 Locating the Upper Junction Box

Call stations, upper gates and interlocks terminate in the upper junction box under the cover at the top of the lift.

Remove the cover from the top of the lift. (Note the lift will not run with the top cover removed) Inside there is a junction box on the right side, remove the cover of this junction box. Inside the junction box there is a cable with individual wires labeled with numbered tags. Number tags are also on the end of the wires coming from the option to be hooked up. Figure 13

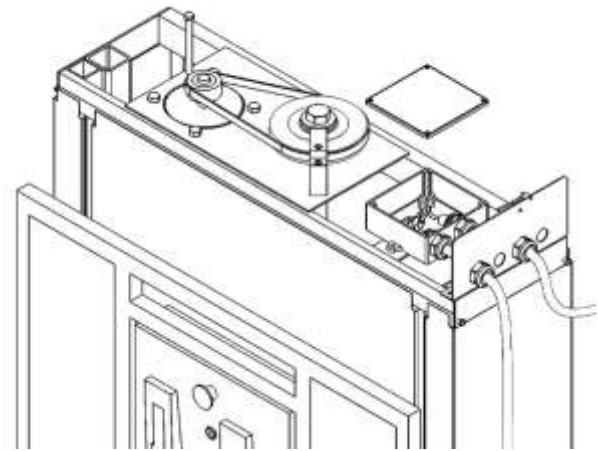

Figure 13: Upper Junction Box

Mount the call station, upper gate and or interlocks into their respective positions.

Run the wires from each option to the upper junction box through conduit. Using the wire nuts provided match the number on the wires to complete the terminations.

⚠ WARNING

Temporarily connect the upper-gate/interlock wire harness and the lower-door/interlock wire harness (if provided) to the matching numbered wires in the outside junction box located on top right hand side of tower. The interlock gate latches must be inserted into the head of the interlock and the interlocks must be set to the locked position for the lift to operate. NOTE: Interlocks and Safety Pan must be connected or the lift will not operate.

See Section 6.4 Installing the Door or Gate Interlock and Section 6.7 installing the Safety Pan.

You will therefore have to use the manual cranking device for down or up movement. The manual cranking device provides an alternate method to move the carriage.

See Page 4 Manual Crank Operation



Temporarily connect the upper-gate/interlock wire harness and the lower-door/interlock wire harness.



6.3 Installing the Door or Gate Interlocks

There are two scenarios for installing interlocks. The first is that the interlock is pre-mounted on a carriage gate or landing gate you have purchased from RAM.

The second is that you have purchased interlocks to mount on doors or gates you will be providing.

Unplug the unit. Disconnect your temporary connections of the upper gate/interlock to the outside junction box- Do not cut the wire numbers off, you will need them again!

Once you have installed conduit (not supplied) and run your wire leads back to the Top Junction Box on the lift. Remove the cover from the top of the lift. (Note the lift will not run with the top cover removed.)

Inside there is a junction box on the right side, remove the cover of this junction box. Inside the junction box there is a cable with individual wires labeled with numbered tags.

Number tags are also on the end of the wires coming from the option to be hooked up. Use the wire nuts provided to match the number on the wires to complete the terminations.



Typical Interlock.

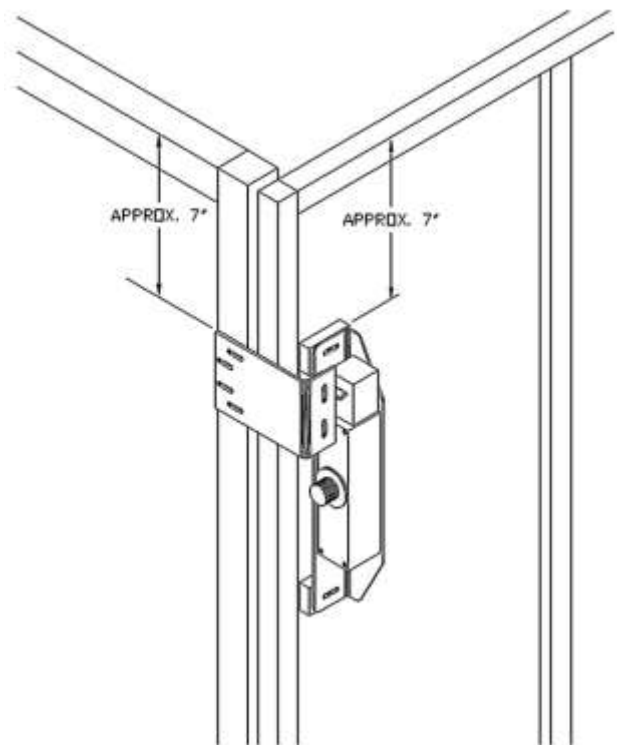

Interlock on Carriage Gate.

6.4 Commercial Lift UPS

Commercial units have a UPS power supply to unlock the gates. For the doors to open properly remove the cover from UPS housing and ensure the UPS power supply is turned on and has charged fully. You will need to re-install the 2 amp fuse (supplied) located in the housing of the UPS in order to operate the UPS.

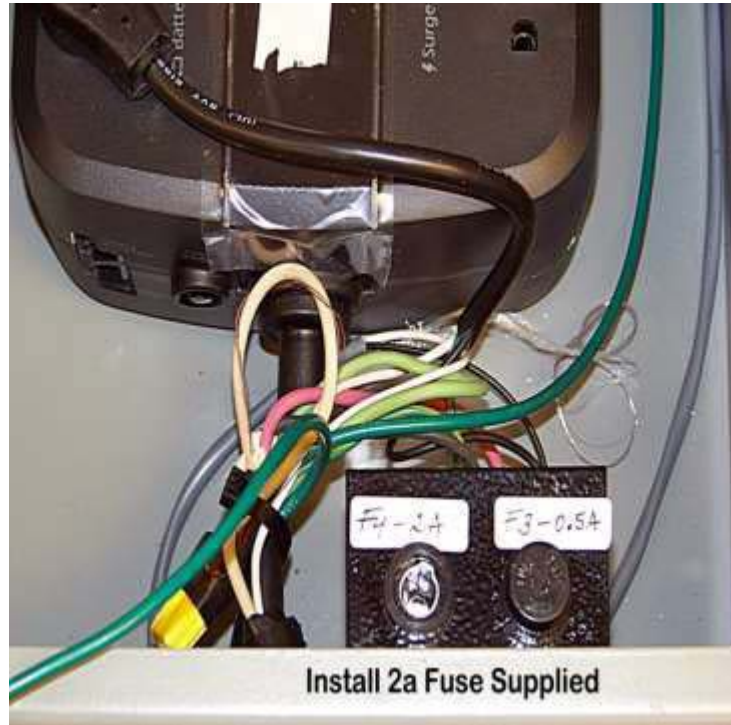

Note that this UPS system is not designed to be backup power supply.

Should you require complete DC backup capabilities then inquire about our Tower of Power DC Backup System.

6.5 Mounting the Interlocks

This section applies to you only if you have purchased Interlocks that will be mounted on doors or gates that are supplied by you or a contractor. This does not apply to interlocks that come on RAM Doors and Gates. Choose the configuration that best works for your application.

Typical Interlock Door or Gate Mount.

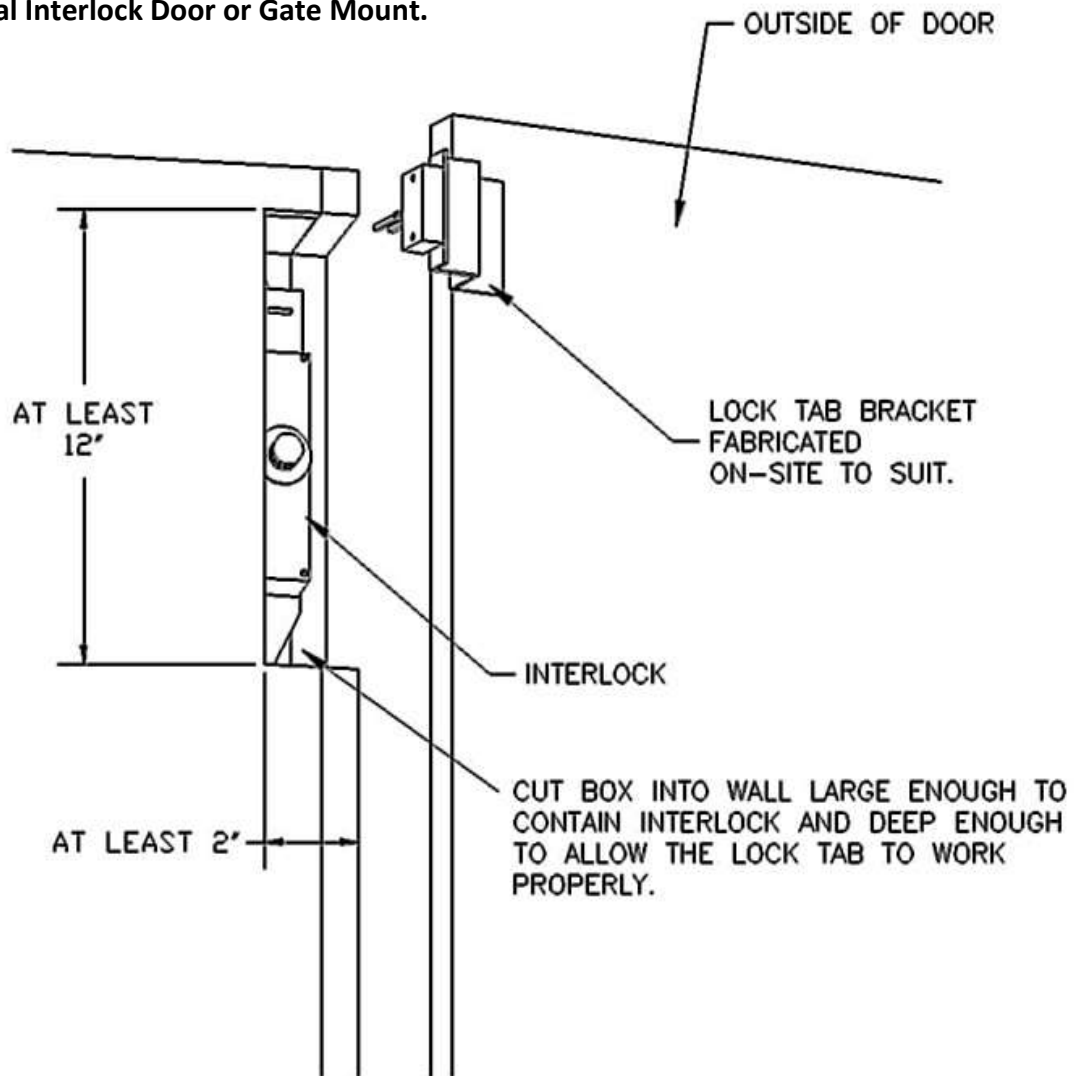

VIEW #1 DOOR OPEN

NOTE:

1. BECAUSE OF VARIATIONS IN CONSTRUCTION METHODS (WALL THICKNESSES, MATERIALS ETC.) ANY INSTALLATION OF THIS TYPE WILL HAVE TO BE CUSTOM BUILT ON-SITE BY THE INSTALLER.
2. THIS TYPE OF INSTALLATION WILL REQUIRE A FLUSH DOOR HANDLE OR PUSH PLATE INSIDE THE SHAFT.

Typical Interlock Door or Gate Mount.

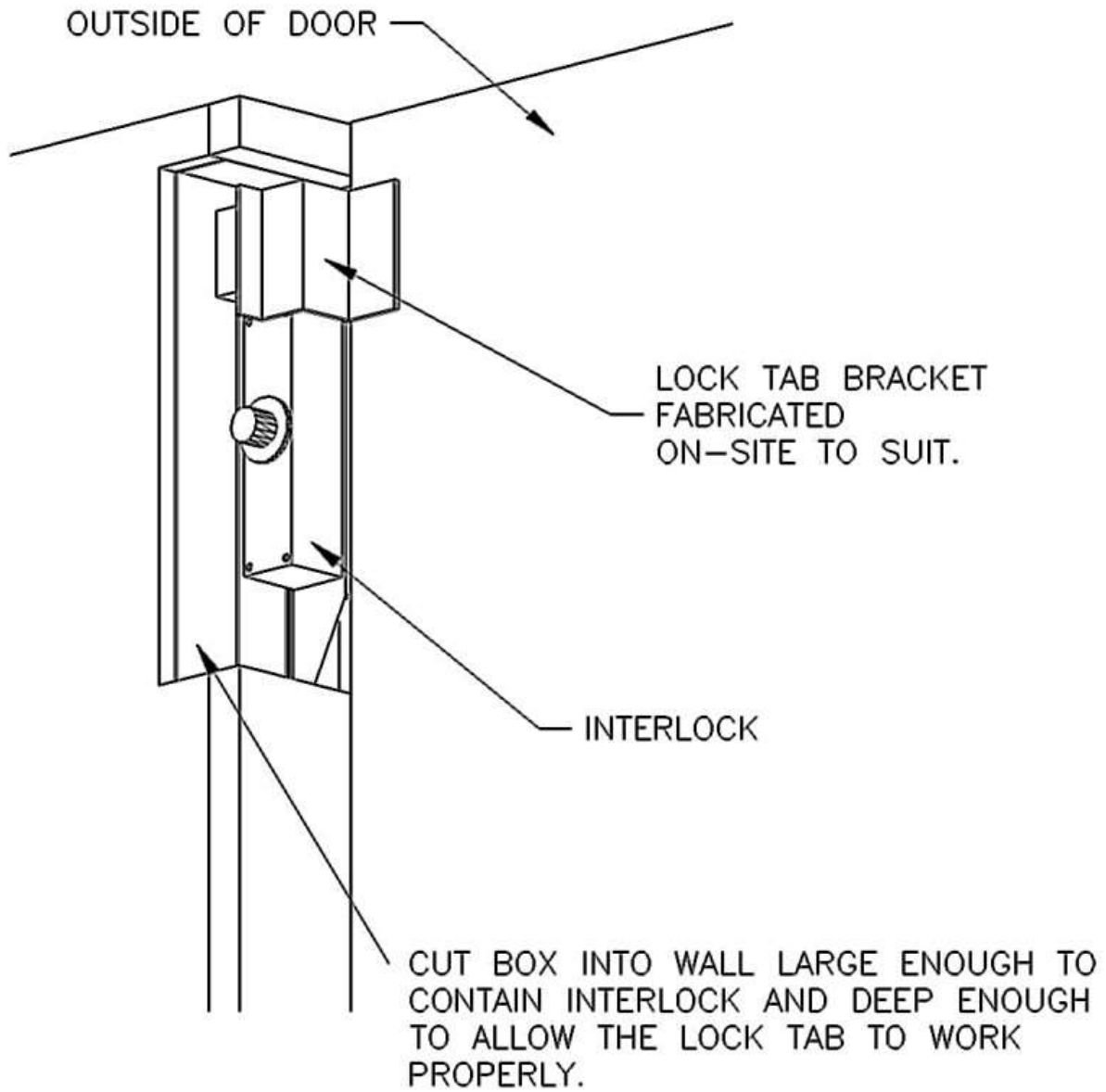

VIEW #2 DOOR CLOSED

Typical Top Floor Door Interlock - Shaft/Hoistway

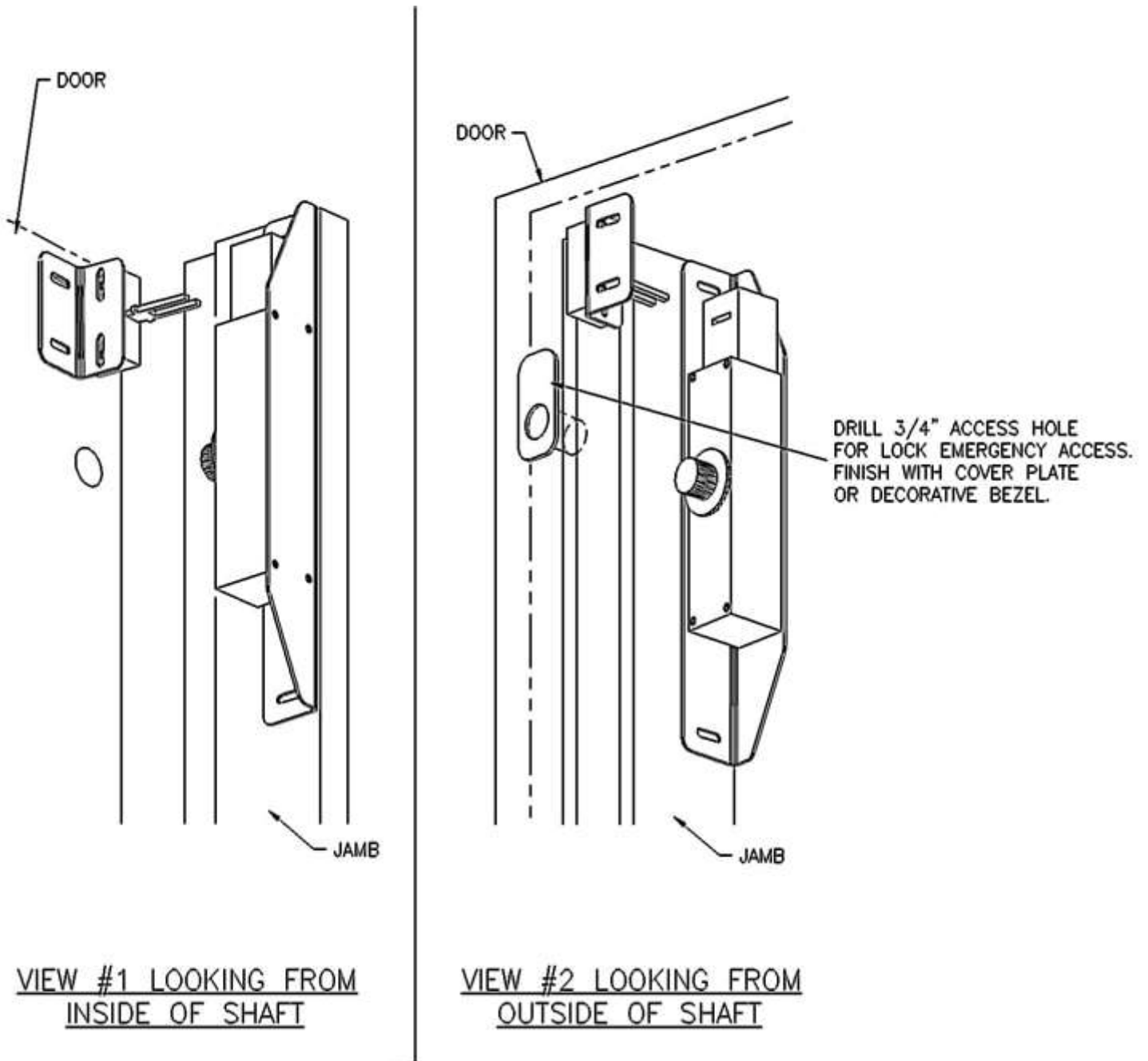

6.6 Installing Remote Call Stations

Unplug the unit or shut off power.

Mount the Lower Remote Call Station in a suitable location.

Disconnect your temporary connections of the Upper Gate/Interlock to the Top Junction box- do not cut the wire numbers off, you will need them again!

Run electrical conduit from the Call Station to the Top Junction Box or the Upper Gate to the Top Junction Box.

Run the cable from the Call Station and the harness from the Upper Gate through the conduit to the Top Junction Box.

Reconnect the wires in the Top Junction Box, this time including the wires from the lower Call Station.

Restore power to the unit.



Typical Push Button Call Station.

6.7 Installing the Safety Pan

Install the lifting platform as per the instructions in Section 5 Basic Lift Assembly.

Remember for movement in the down direction prior to having the platform installed you will need to use the manual crank to lower the device.

Once platform is bolted on then plug the Under Deck Safety Limits into the Inside Junction Box located on the Guide Frame (as shown.) Once plugged in the unit will now run up and down without having to use the manual crank.



Plug in the Under Deck Safety Pan.

6.8 Installing the Control Wall Extension

Mount the Control Wall Extension to the Guide Frame as shown.



Mount the Control Wall Extension.

6.9 Installing the Solid Hand Rail Straight Platform

For a Straight Access Unit Mount the Solid Handrail to the Carriage as shown.



Lower the Handrail into Place.

See Section 6.10 for Adjacent Platform

Nuts and Bolts are pre-mounted.
Undo – Lower Handrail into place and re-insert bolts.



Bolt Handrail to Platform.



6.10 Installing the Solid Hand Rail Adjacent Platform

For an Adjacent Access Unit Mount the Solid Handrail to the Carriage as shown. The safety pan must be lowered to access the mounting holes.

After mounting the Solid Handrail attach it to the Control Wall Extension using small 1" Angle, remount safety pan to finish.

All required hardware is pre-mounted.



Mount the Adjacent Handrail.



6.11 Installing the Carriage Gate

Lower Safety Pan to Access Bolt Hole.

Mount the Carriage Gate to the Control Wall Extension as shown. Match the hinges to the holes on the Control Wall Extension.

Fasteners- Pre-mounted on the hinges of the gate.



Mount the Carriage Gate.

On Adjacent Units mount the corner post as shown. Square it to Carriage Gate, if necessary shim with washers provided.



For Adjacent Unit, Mount Corner Post

6.12 Installing the Carriage Gate Interlock

Mount the Carriage Gate Interlock to the Solid Hand Rail for a Straight Unit or to the Corner Post for an Adjacent Unit as shown. Then remount the interlock tab to the gate door latch.



Adjustment of the Interlock Key Tab may be necessary to allow proper alignment, 2 screws mounting it to the Aluminum Gate Tab and adjust if necessary as shown.

The alignment should be done initially with 50% of expected working load centered on the platform. Then check with 0 load and 100% load to verify that the interlock will latch properly.



Adjust Gate Hinge to Self Close. (next page)



Adjust the Spring Loaded Hinge on the Carriage Gate as shown, this allows the gate to self-close against the Interlock.

Use a 5/32" Allen Key to release the tension on the loaded pin (turn clock wise). Remove the set pin from the hinge.

Increase tension (clock wise) or decrease tension (counter clock wise) and reinsert the set pin.



Adjust the Spring Loaded Hinge.

Fasten the Carriage Gate Interlock Cable to the underside of the Toe Plate Angle using the plastic Nylon Tie Straps provided as shown.

Fasten Cable with Tie Straps.



6.13 Adjusting Mechanical Stops

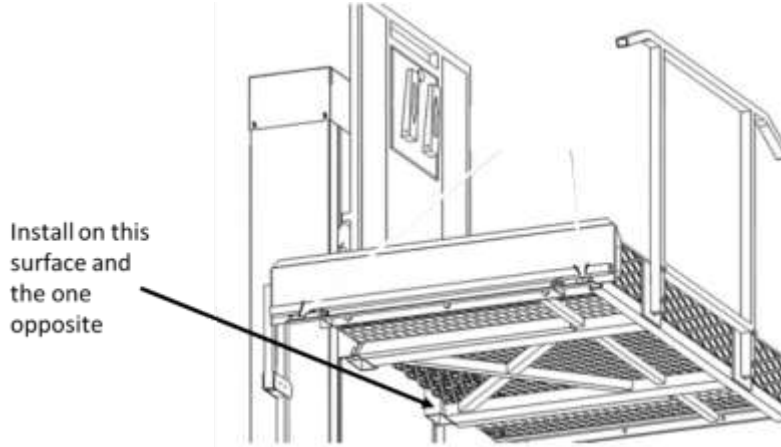

Your lift may come equipped with mechanical stops.

These stops should be pre-installed at the factory but will be in a fully retracted position.

They need to be adjusted on site to ensure proper operation of your lift.

This is particularly important if you have a solid platform that is also equipped with a safety pan.

The lift should come to a rest on the mechanical stops evenly and you adjust the stops by loosening the jam nut and then rotating the large bolt in the appropriate direction to raise or lower them.

If you do not adjust these bolts properly the interlocks, should your lift be equipped with them, will not function properly.

Please see figures to the side indicating the parts and where they are located



6.14 Mounting the Upper Landing Gate

Mount the Upper Gate to the threshold at the upper landing as shown.

Drill through the 4" X 4" Angle on the Upper Gate frame at suitable locations to provide adequate mounting holes for the angle, lag bolt or screw into place. OR Use a Polyurethane Adhesive to mount the threshold to the upper landing.



Drill Through Both Angle Edges to Fasten Gate to Threshold.

Use a Polyurethane Adhesive to mount the Upper Gate Post uprights to the existing structure as shown.

When using the Polyurethane Adhesive, adequate clamping and support must be in place until the adhesive sets properly. (NOTE CLAMP IN PICTURE)



Use Adhesive to Fasten Gate to Existing Structure.

Section 7: Mounting the Tower to a Wall

On Commercial applications and Tall Tower installation you will be required to attach the tower to a wall or support. Your code requirements may vary so check with your governing authority.

Basic Wall Mounting

Using Lag Bolts (wood Lag Bolts are Supplied with Lift)

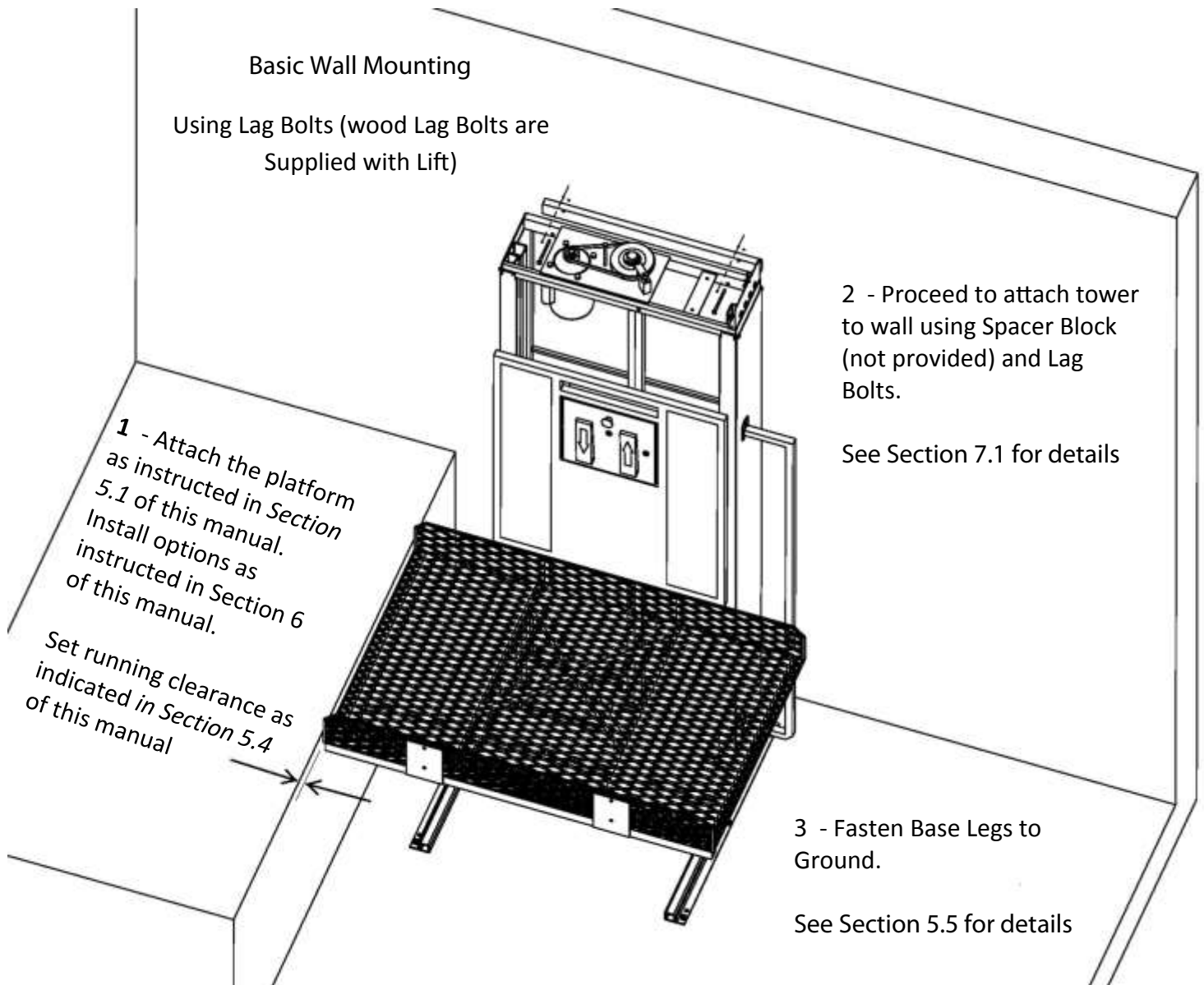

7.1 Installing the Spacer Block for Wall Mount

Spacer Block (Not Provided) is required to maintain space behind Top Cover in order for Top Cover to be removed for maintenance etc

See Sections 7.2 & 7.3 for details

Using a 1/4" bit, drill through existing hole in frame, through back cover panel and spacer block
DO NOT DRILL INTO WALL WITH THE 1/4" BIT

If pre-drilling wall with pilot hole for lag bolt, use 1/8" drill bit

Existing Hole in Frame

Lag Bolt
(The bolts provided with the lift are to be used for wood only)

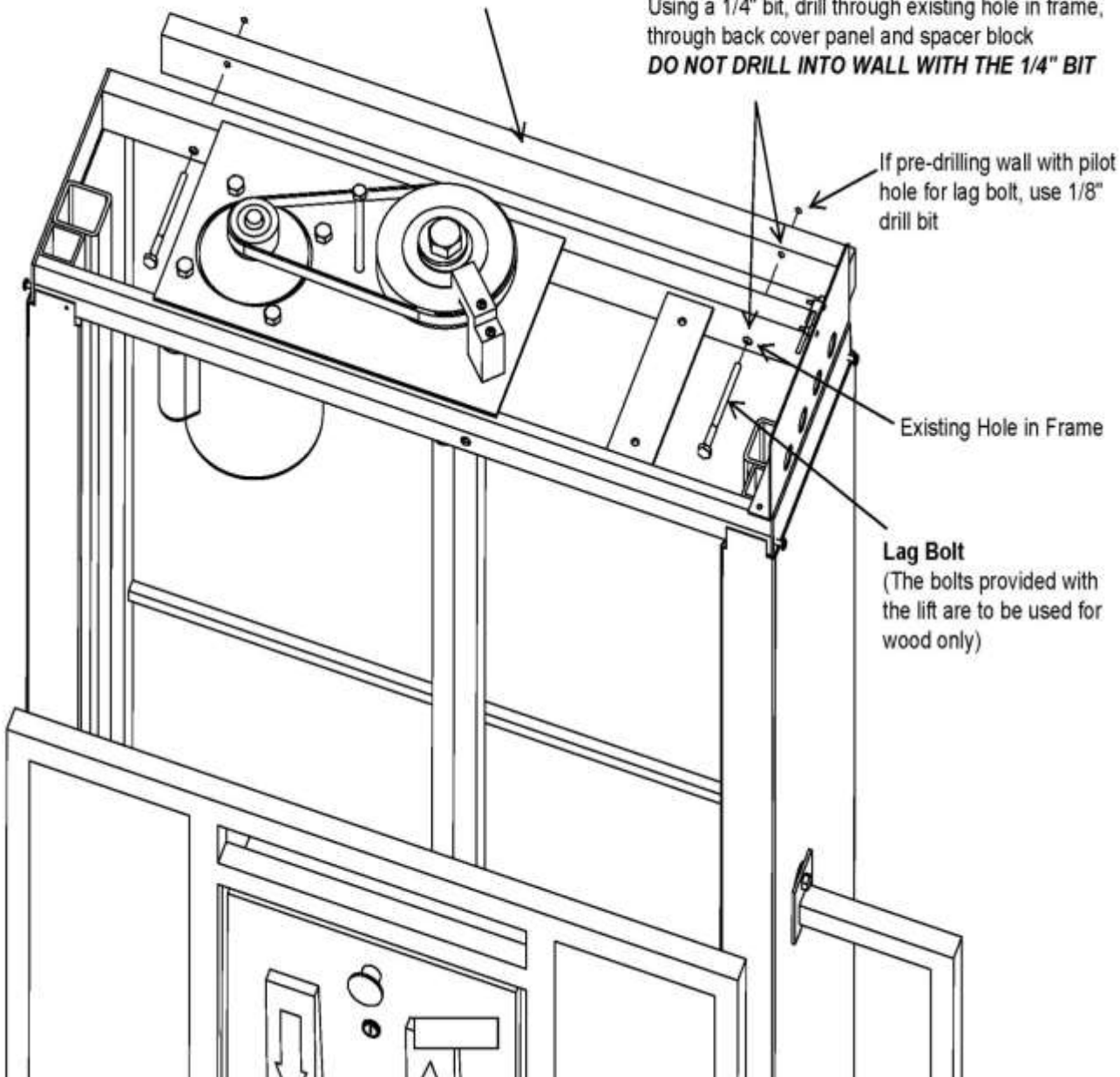

7.2 Spacer Block Placement

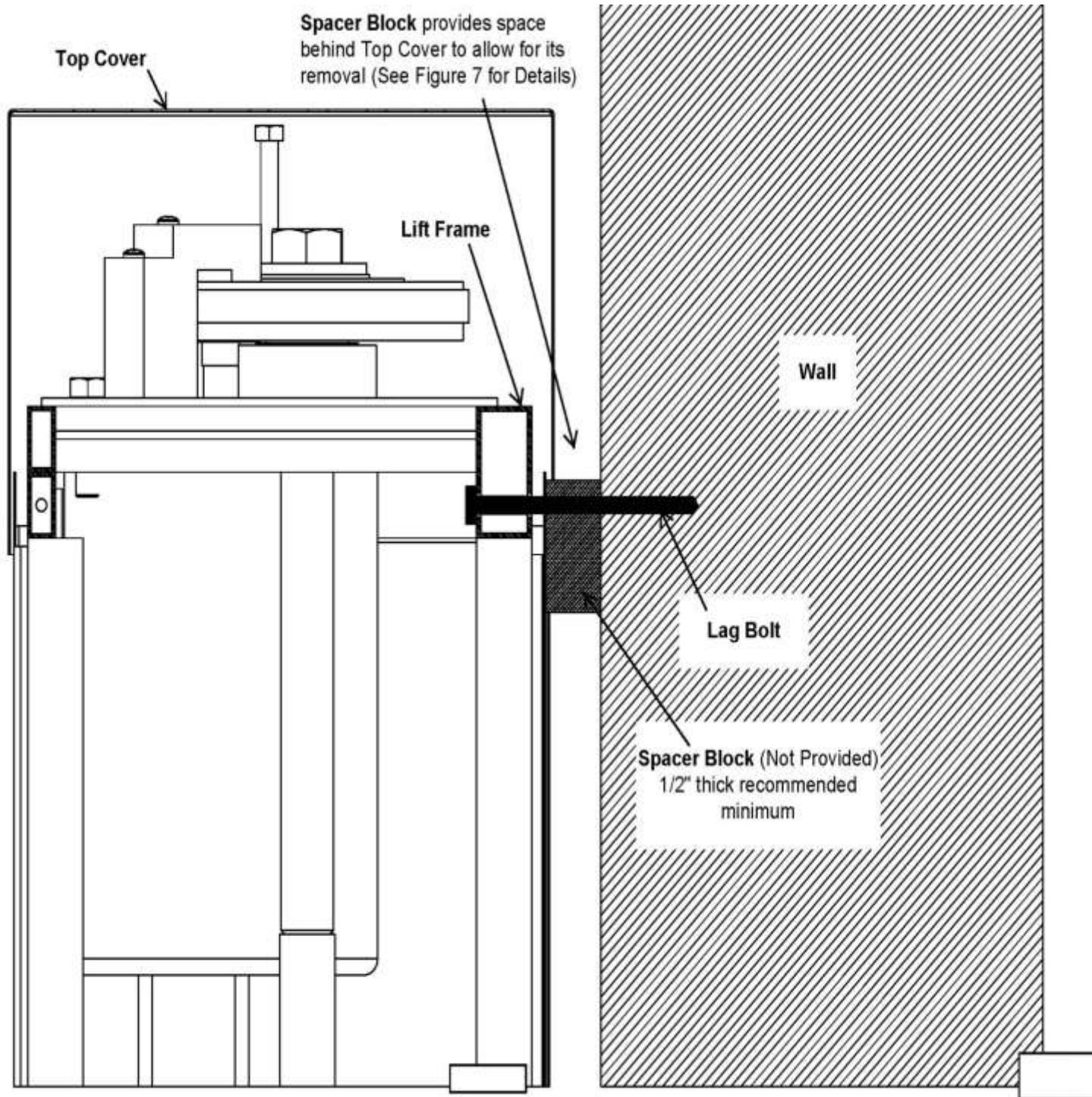

7.3 Spacer Block Installed View

Note that the Spacer Block does not interfere with the removal of the Top cover.

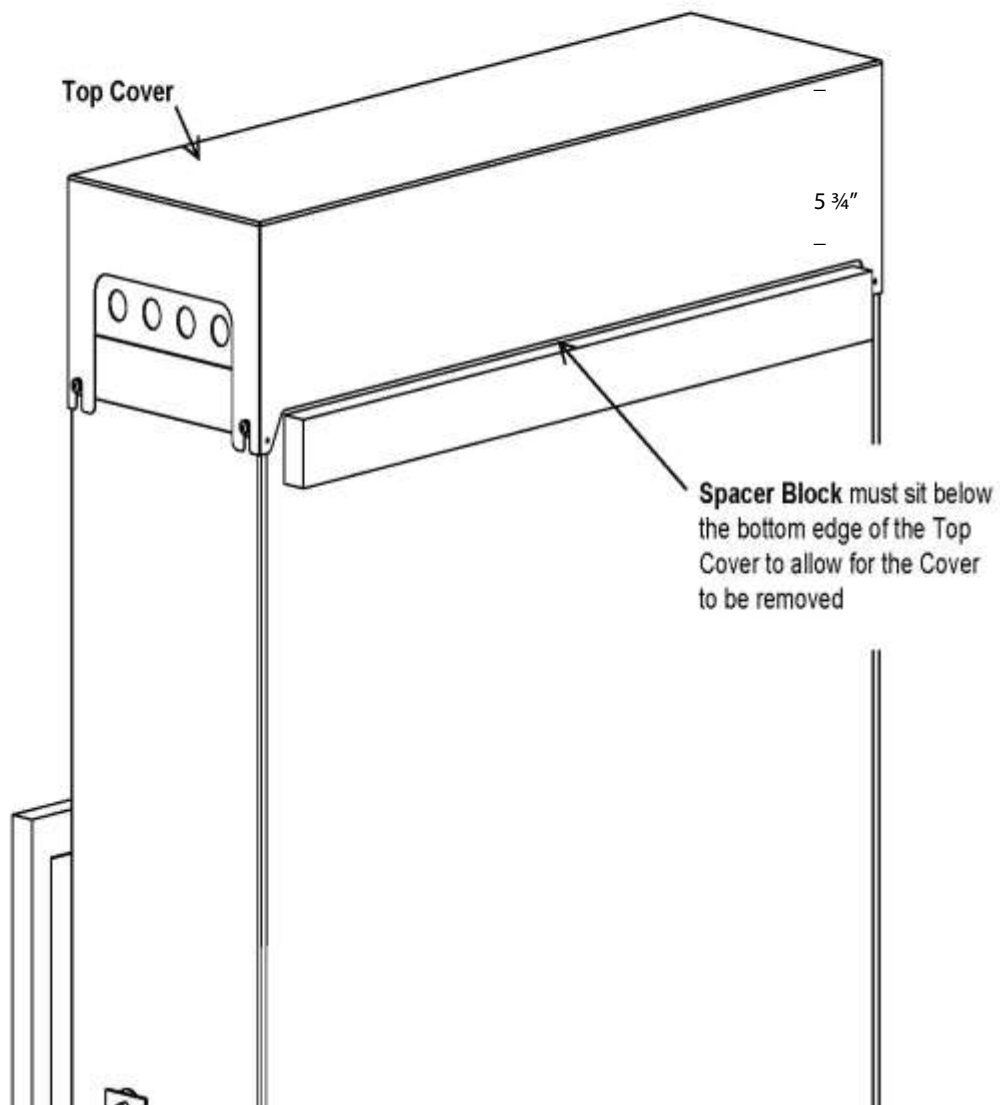

Section 8: Tall Tower Lifting Instructions

Working with Tall Towers can be difficult and dangerous if done incorrectly. This is the recommended method and should be followed at all times. Failure to do so can result in serious injury or death. Under no circumstance should you attempt to lift or maneuver a Tall Tower unit by muscle power alone.

8.1 Lifting Tools Required.

Using the right tools will decrease your chances of having an accident. However no tool can replace forethought or common sense. Always plan your project well in advance.

- Spreader Bar – Ensure that the Spreader Bar you are using is rated for the weight of the lift you are attempting to lift. Confirm the unit weight with RAM before lifting.
- 2 – 500 lb. Capacity Lifting Straps – Only straps that are in good condition should be used. Do not use frayed or worn straps as their capacity may be compromised.
- Lifting Device. Remember that whatever device you intend to lift the unit is weight rated properly. Check with the supplier of this device if unsure.

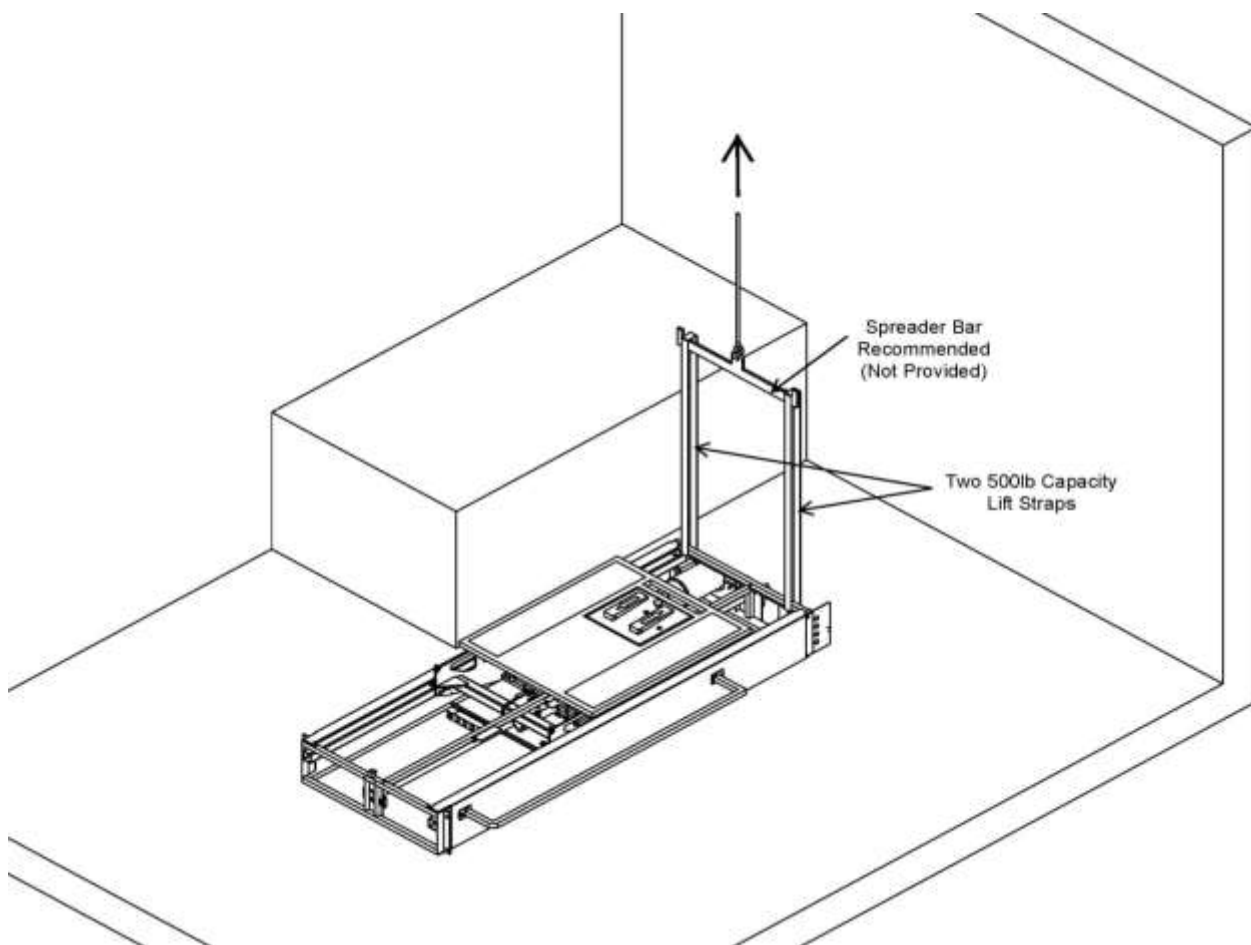

8.2 Locating the Lifting Straps

The lifting strap placement is critical. Failure to use the recommended locations can produce unpredictable results. Confirm proper placement before attempting lift.

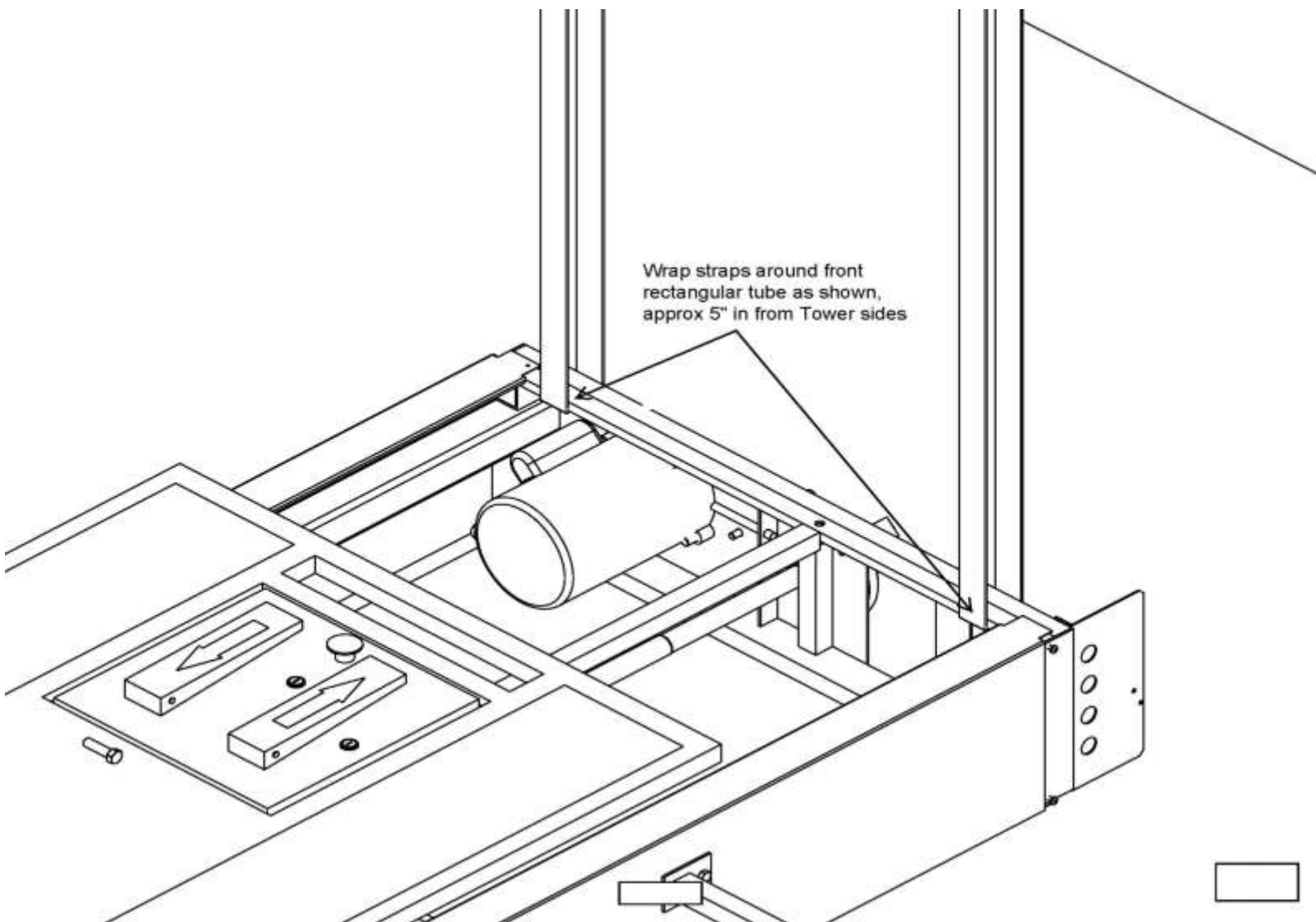

8.3 Releasing the Lifting Straps

Once you have completed raising the unit you must attach the Base Legs to the Tower. This is done BEFORE you release the lifting straps. **DO NOT ATTACH THE BASE LEGS TO THE GROUND AT THIS TIME.** See Section 5 BaseLeg Installation.

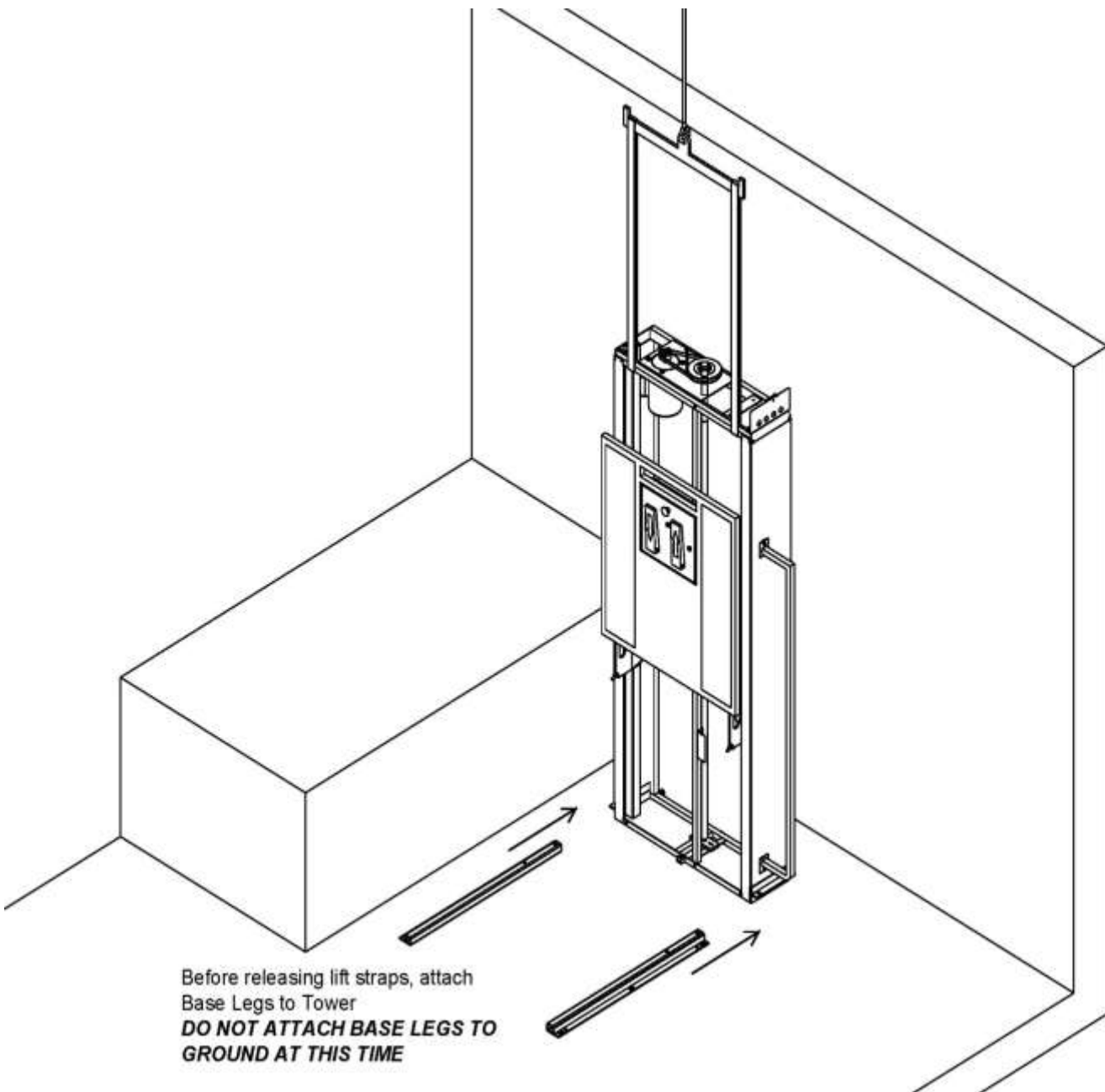

Section 9: Maintenance

9.1 Monthly Inspection:

9.1.1 Inspect all gates/doors and ensure they are locked when the lift is not at the landing. Also check that the lift will not run unless the gates / doors are fully closed and locked once the platform is more than 2" (50mm) from the landing.

9.1.2 Inspect the toe plate and ensure it is operating smoothly and moving into the up position when the lift leaves the lower landing

9.2 Annual Maintenance:

The Trus <T> Lift should be inspected and maintained annually. The following is a non-exhaustive list items that should be checked as part of an annual maintenance in order to maintain safe operation of your lift. An inspection and maintenance is required to be completed by an authorized RAM dealer for any extended warranty claims to be valid.

9.2.1 Inspect the drive nuts

Compare the amount of movement in the drive nuts from side to side and up and down without rotating the drive nut at all. If they feel overly sloppy or as though threads may be missing then they need to be replaced. Signs of bronze thread material or shavings are another indicator of worn lifting nuts. If the amount of movement is minimal spin the drive nuts by hand to check for resistance, if any resistance is felt or the drive nut binds then they must be replaced. Refer to Replacing the Drive Nuts Section 9.3

9.2.2 Inspect the drive screw

Inspect the drive screw for any irregularities, sharp edges or foreign objects and dirt caught in the threads. Be sure no damage exists to the drive screw and that it is entirely clean of debris. Replace screw if damaged.

9.2.3 Clean and re-lubricate the drive screw

In order to lubricate the drive screw you must remove the main front panel and a carriage guide frame panel (Fig M1 and M2). Use a clean rag to wipe all of the grease off of the screw. Liberally apply Mobil SHC-460 grease on the drive screw by hand.

9.2.4 Inspect the drive belt

Remove the top cover and inspect the drive belt for wear. A small amount of black rubber bits below the belt is normal. If there is any significant sign of wear to the belt, replace.

9.2.5 Inspect for surface damage and complete touch ups to coatings

Wear and tear may occur on powder coated steel surfaces resulting in scratches. Small points of damage can be wire brushed and touched up with the small touch up paint containers that come with each lift RAM ships out. This will extend the life and cosmetic look of you lift and is particularly important in any environments that are coastal or potentially corrosive.

9.2.6 Inspect cables

Tears in insulation should be patched where possible and if bare wire is present new replacement cables should be purchased and installed by a qualified technician. Consult your RAM dealer for spare parts should they be required.

9.2.7 Inspect for correct functioning of toe plate – if applicable

The tow plate actuation mechanism may be critical to access and the both the mechanism and the toe plate itself should be examined. If there are any concerns adjust the mechanism or repair/ replace it.

9.2.8 Re-check platform alignment and clearances

Buildings and construction “settles” over time and adjustments may be required to ensure good clearances and alignment of the lift. Consult the appropriate sections of the installation manual or RAM’s technical support team for guidance.

9.2.9 Inspect and Test All Interlocks and Safety Devices

Interlocks and all other safety devices should be tested to ensure they work in the appropriate manner. If you are uncertain whether they are operating correctly please consult with your RAM dealer or call RAM’s technical support team.

9.3 Replacing the Drive Nuts

Should the main drive nut become worn or fail you will have to replace it. Note that both the Backup Drive Nut and Main Drive Nut are replaced at the same time. Never replace only one nut.

Note that the platform of the lift must be blocked up high enough for you to work under. Use the manual crank to lift the platform and guide frame and prop it up using a 2x4 or shoring device. It is not necessary to remove the platform but can be done if you need more working space. The platform **MUST BE SECURED** with a chain or belt rated for a minimum of 1000 lbs. This is necessary in case the 2 x 4 slips while working under the platform

9.3.1 Disconnect Power or Unplug the Lift.

9.3.2 Un-assemble the Lift in the following order.

Remove the Top cover



Remove the Guide Frame Covers



Remove the
Front Panel



Remove the
Back Panel



9.3.3 Remove the
Break Block



9.3.4 Remove the Drive Belt



9.3.5 Block the Drive Shaft



9.3.6 Ensure that Drive Shaft is clear of Guide

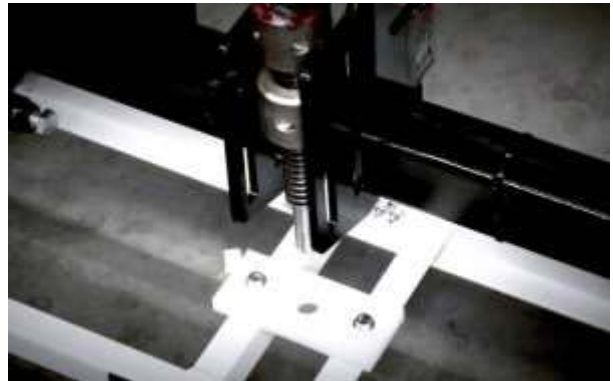

9.3.7 Undo all Drive Nut Bolts Top & Bottom

9.3.8 Remove the Red Safety Bracket



9.3.9 Measure Distance from Bottom Nut to End of Screw

Make note of this measurement for later



9.3.10 Measure the Distance
Between Nuts

Make note of this measurement for later



9.3.11 Pull Drive Shaft
Forward and Spin
Off Nuts



9.3.12 Clean Old Lubricant
of Entire Screw. Use a twisting
action to ensure proper cleaning



9.3.13 Apply New Lubricant
to Screw and Drive Nuts



9.4 Spin On New Drive Nuts



9.4.1 Ensure Bottom Nut is the Correct Distance from End of the Screw. Measure the Distance between Drive Nuts – Ensure Proper Spacing. Use the measurements you noted earlier.



9.4.2 Unblock the Drive Shaft



9.4.3 Ensure Bottom of Shaft Aligns with Guide



9.4.4 Replace Safety Bracket and Tighten Drive Nut Bolts

Be sure to replace the lower limit switch rod



9.4.5 Replace Drive Belt



9.4.6 Replace Break Block



9.4.7 Power on the Lift Test Operation. Note that top cover switch must be depressed or lift will not operate. Never attempt to operate the lift with the top cover off.



9.4.8 Reassemble the Lift

Replace the Back Panel

Replace the Front Panel

Replace the Guide Frame Covers

Replace the Top Cover (Ensure that Top cover switch is properly depressed or lift will not operate .)

Lower Platform

9.5 Maintenance Log:

Please keep a record of all maintenance done on the lift in the maintenance log provided in Appendix C.

Section 10: Basic Trouble Shooting

10.1 Replacing a Fuse

Unplug the power cord.
 Open the control box with the key provided (this is the key numbered 644).
 The fuses are located in the control box on the right hand side. Replace the blown fuse with a fuse with the same Amp rating.



10.2 No Power to the lift. Lift will Not Operate

Check to see if the lift has been plugged in or the power supply has been hooked up. Check if emergency button is depressed. Pull to “on” position. Ensure that the power key on the control panel is in the “on” position. If you have interlocks ensure they are in the “locked” position. Check that the Top cover Switch is properly depressed by removing the top cover and inspecting the switch.

10.3 Lift Runs Up and Not Down

Ensure that the Lower Limit Switch Rod is resting inside the Red Safety Bracket. Check that the Safety Pan has not been activated. Safety Pan must be Free Floating.

10.4 Lift Runs Up and Down but Doors or Gates will Not Unlock

Check to see that interlocks are properly mounted, and latches properly mate with the interlock. For Commercial lifts the UPS must be turned on or the doors will not open.

Contact RAM Tech Support for other issues.

Please have your serial number ready. Located inside of the control panel door.

Appendix A: Trus <T> LIFT Assembly Drawings (with part numbers)

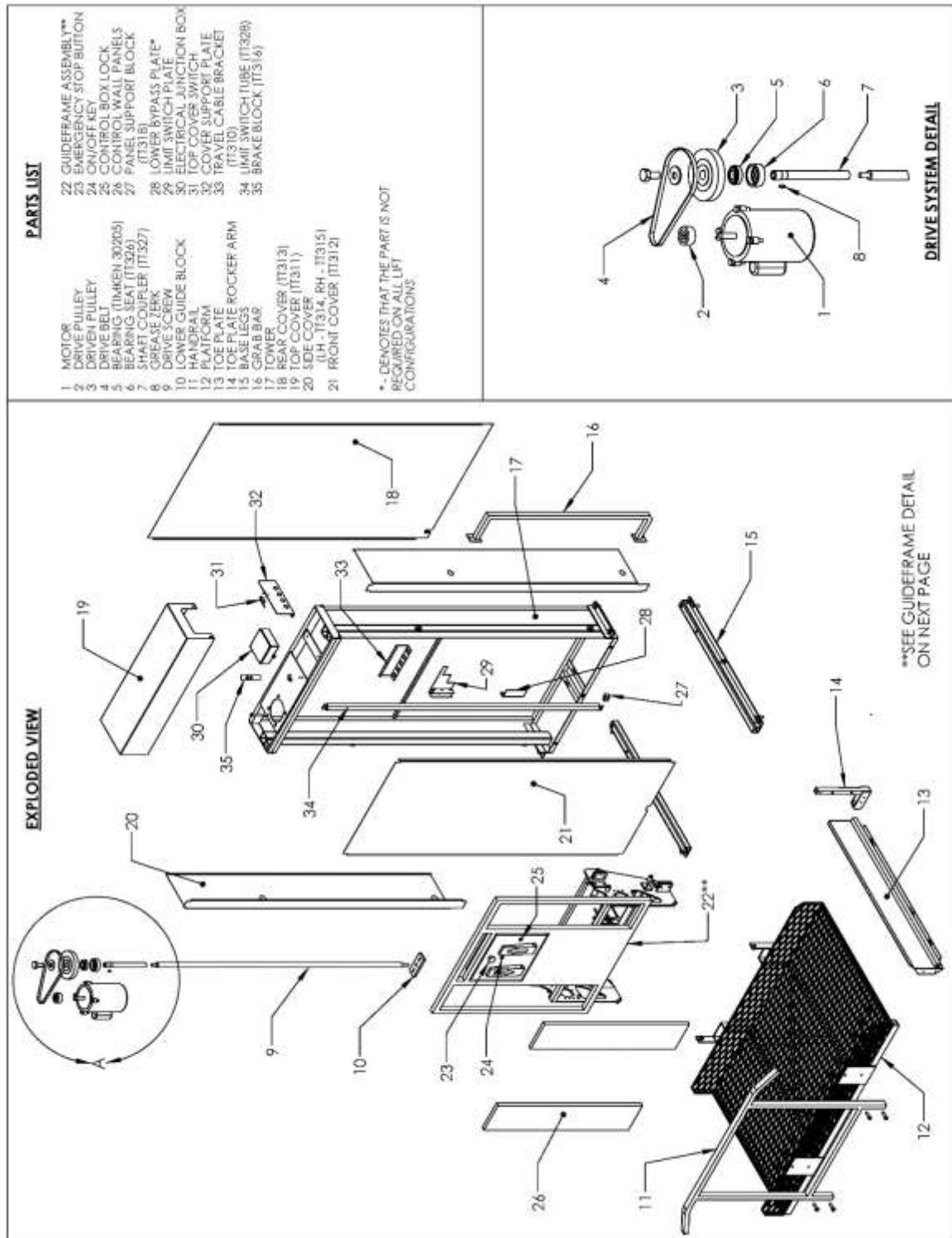

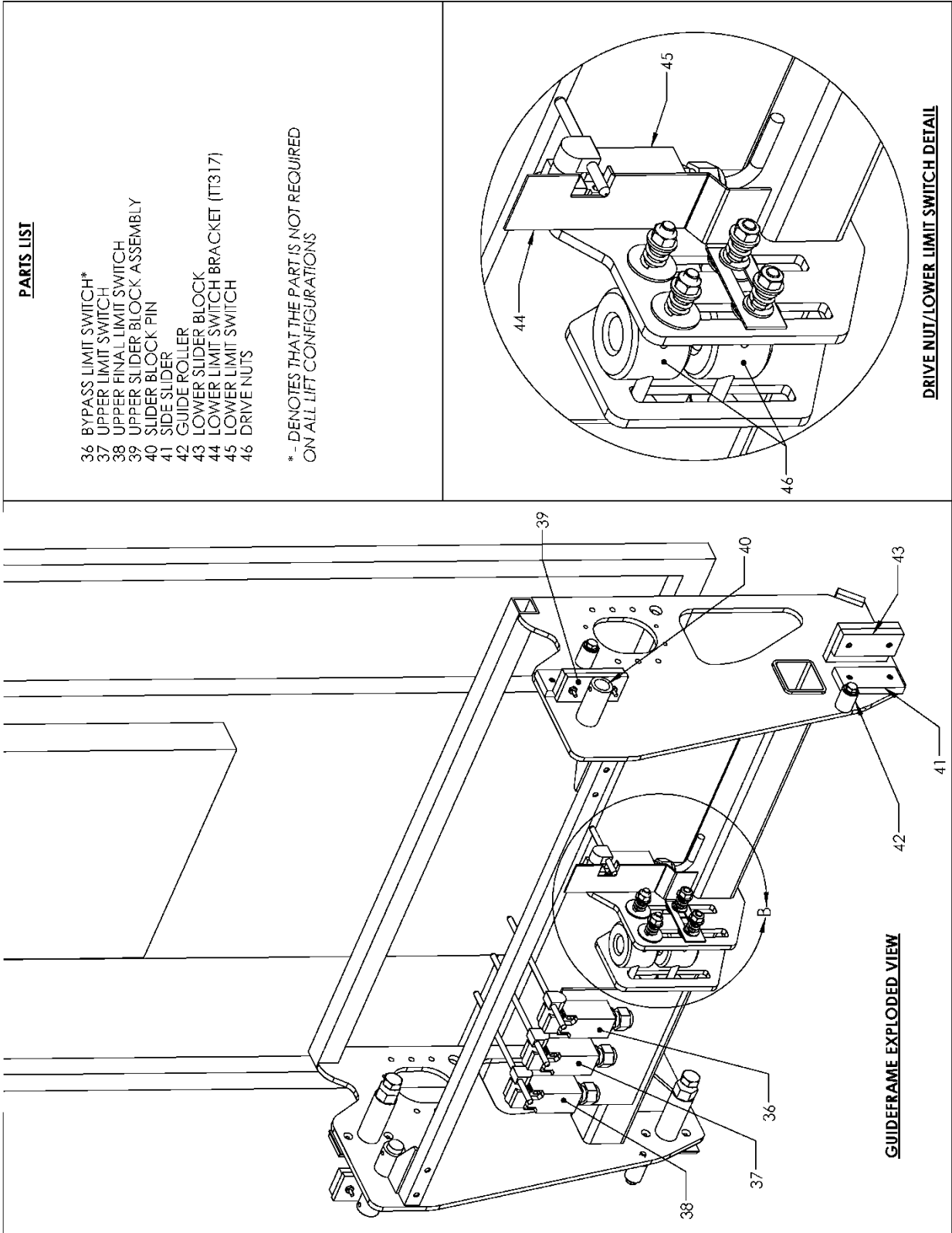

Upper Landing Gate Drawing (with part numbers)

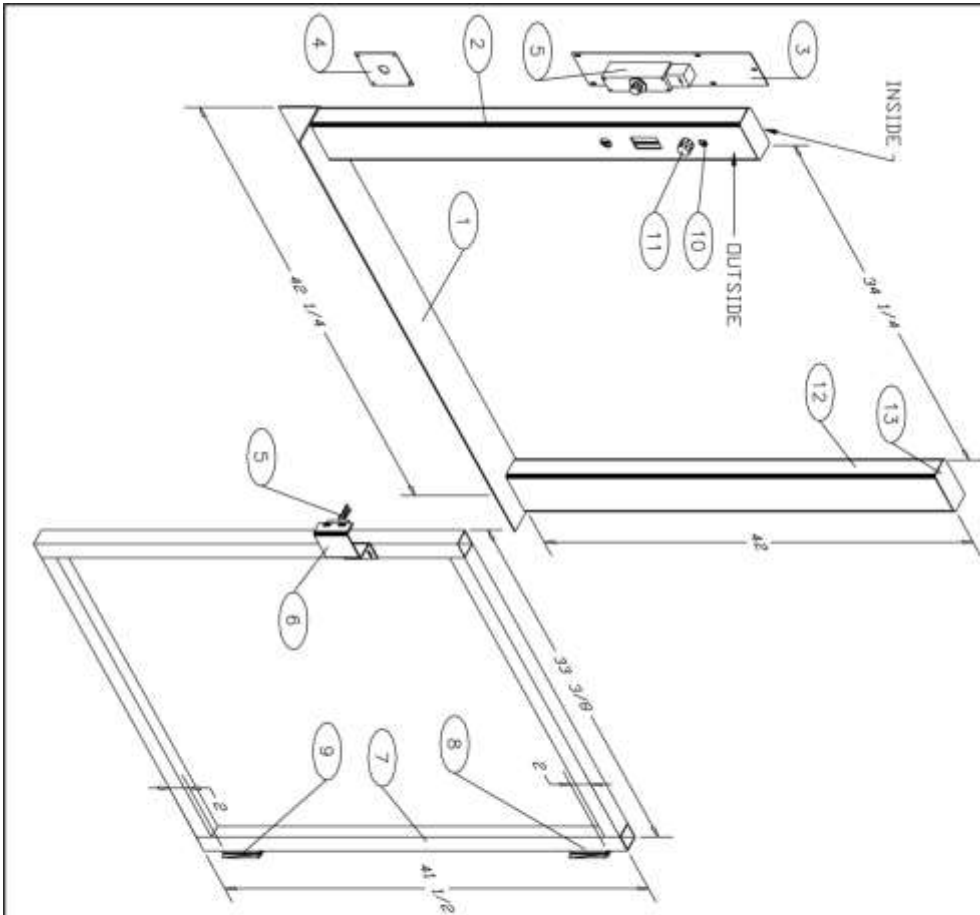

PARTS LIST

| ITEM QTY | PART NUMBER | DESCRIPTION |
|----------|-------------|--------------------------------------|
| 1 | FFBTC143 | GATE ASSEMBLY ANGLE - 4X2 POST |
| 2 | FFBTC142 | GATE ASSEMBLY - 4X2 POST |
| 3 | FFBTC144 | GATE INTERLOCK MTG PLATE 4X2 POST |
| 4 | FFBTC145 | GATE POST CONDUIT ENTRY PL. 4X2 POST |
| 5 | 44534-1187 | STI TL4019 110VAC Interlock Kit |
| 6 | FFBTC146 | GATE LOCK BRACKET - 4X2 POST |
| 7 | FFBTC092 | GATE |
| 8 | 1 | 3 1/2" SPRING LOADED HINGE |
| 9 | 1 | 3 1/2" HINGE |
| 10 | 1 | KEY SWITCH |
| 11 | 1 | PUSH BUTTON/TOGGLE |

MATERIAL LIST

| ITEM QTY | DESCRIPTION | MAT'L |
|----------|---------------------|--------|
| 12 | 4 X 2 HSS X 42 LG | HSS |
| 13 | 1/8 X 2 F.B. X 4 LG | H.R.S. |

NOTE:
GATE IS FLUSH WITH THE INSIDE OF THE POST.

| | | | |
|-------------------------------|--------|--|-------------|
| REV | BY | DATE | DESCRIPTION |
| RAM MANUFACTURING LTD. | | | |
| DWN. BY: B. HANNAH | | TRUS-T-LIFT GATE ASSEMBLY - 4X2 POSTS | |
| CHECKED BY: | | STI INTERLOCK | |
| SCALE: | N.T.S. | DATE: | 15/12 /04 |
| | | DRAWING No. | AFBTC141 |
| REV | A | | |

Appendix B: Basic Electrical Drawing

Note: For lifts with options the electrical drawing specific to the options provided will be sent with the lift.

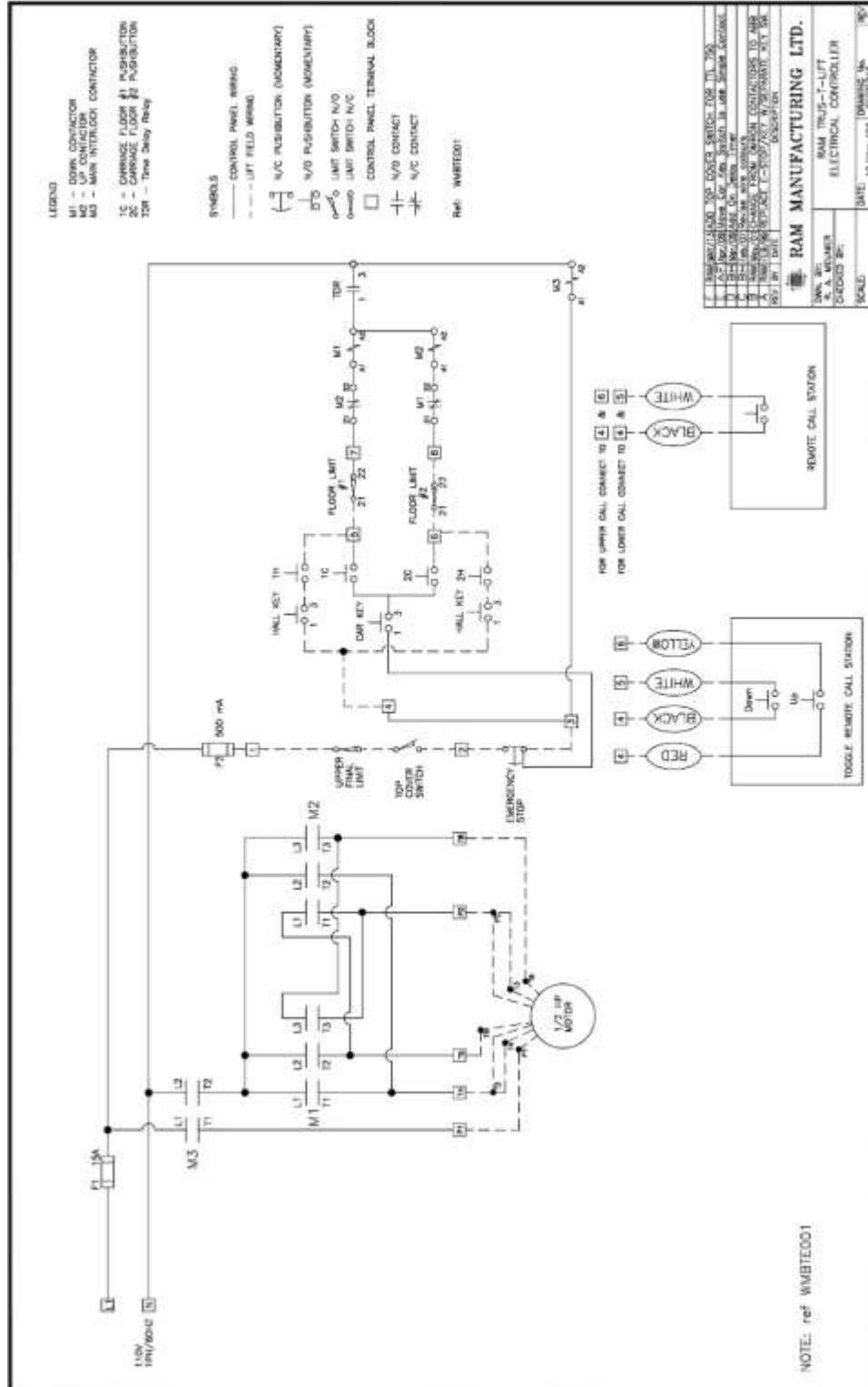

Appendix C: Required Tool List

Hammer
3/8" Drive Ratchet
3/8" ratchet drive x long 6" Extension
3/8" Drive Sockets- 3/8", 7/16", 1/2", 9/16", 3/4", 7/16", 15/16" Deep (15/16" socket will come with the lift originally)
Combination Wrench- 3/8", 7/16", 1/2", 9/16", 3/4"
Wire Cutters
Wire Strippers
#2 Robertson Screwdriver
Flat Blade Screw Driver
Terminal Block Screw Driver (0.6x3.5)
#2 Phillips Screwdriver
Tape Measure
24" Pry Bar – suggested only
1 1/2" Adjustable Crescent Wrench
1/8" Allen Key
Small Magnetic Level
Utility Knife
Electrical Meter (Amperage/Voltage/Resistance) – suggested only

Other Recommended (for securing to masonry and concrete):

Concrete Drill
3/8" Concrete Bit

Appendix D: Maintenance Log

| Date | Description | Signed |
|-------------|--------------------|---------------|
| | | |
| | | |
| | | |
| | | |
| | | |
| | | |
| | | |
| | | |
| | | |
| | | |
| | | |
| | | |
| | | |
| | | |
| | | |
| | | |
| | | |
| | | |
| | | |